



**European Committee
of the Regions**

Visual identity guidelines

European Committee of the Regions

March 2025

Table of content

CHAPTER 1

Visual elements

Logo	6
› Composition.....	6
› Language versions.....	7
› Proportion.....	8
› Typography Colour palette.....	9
› Clear Space area.....	10
› Alternative colour versions – negative version Background rules.....	11
› Minimum size Mute logo.....	12
› Misuses of the logo.....	13
› Multilingual logo.....	14
› Co-branding with the European institutions and CoR political groups.....	16
Graphic Line	17
› Main and secondary typography.....	17
› Alternative typography for Office Titles system and rules.....	18
› Graphic elements – white diamond shape.....	19
› Graphic elements – grid system.....	20
› Grid system – portrait format.....	21
› Grid system – landscape format.....	22
› Co-branding with partners and for events.....	23

CHAPTER 2

Printed media

Stationery	26
› Letterhead.....	26
› Business card.....	27
› Compliment card.....	28
› Invitation.....	29
› Envelopes.....	30
› Electronic signature.....	32
› Document folder.....	33
› Power Point slides.....	34
› Notepads.....	36
› Promotional items.....	37
CoR Publications	38
› Brochure – grid system for cover.....	38
› Brochure – examples of covers and backcovers.....	39
› Brochure – grid system for interior page layout.....	42
› Brochure – examples of interior page layouts.....	43
› Leaflet – grid system for cover.....	45
› Leaflet – examples of covers and backcovers.....	46
› Poster – grid system.....	48
› Poster – examples.....	49
› Signpost – grid system.....	50
› Signpost – examples.....	51
› Badges – grid system and examples.....	52
› Roll ups and stands.....	53
› Infographics – grid system.....	54
› Infographics – examples.....	55
› Factsheet – grid system.....	56
› Factsheet – examples.....	57
› CoR identity on political groups publications.....	58

CHAPTER 3 Digital media

Digital media	62
› Social media – Facebook, LinkedIn.....	62
› Social media – Instagram, Flickr.....	63
› Social media – YouTube, X.....	64
› Social media – posts and CoR logo.....	65
› Press release.....	66
› Joint press release.....	67

CHAPTER 4 Commissions of the CoR

Commissions of the CoR	70
› Visual identity of CoR commissions.....	70
› Layout structure for commissions' visual identity.....	71
Stationery	72
› Document folder – grid system.....	72
› Document folder – examples.....	73
› Roll up – grid system.....	74
› Roll-up – examples.....	75
› Power Point slides – grid system.....	76
› Power Point slides – examples.....	77
Publications	78
› Brochure – grid system for cover.....	78
› Brochure – example for each commission.....	79
› Studies – grid system.....	80
› Studies – examples.....	81
Digital media	82
› Social media – visual quotes templates.....	82
› Social media – posts.....	83
Conferences	84
› Poster – grid system.....	84
› Poster – examples.....	85
› Programme – grid system for cover.....	86
› Programme – example for each commission.....	87
› Programme – grid systems for content page(s).....	88
› Programme – examples.....	89
› Power Point slides – grid system and examples.....	90
› Signpost – grid system and examples.....	91
› Badges – grid system and examples.....	92

CHAPTER 1

Visual elements

Logo

› Composition.....	6
› Language versions.....	7
› Proportion.....	8
› Typography	
Colour palette.....	9
› Clear Space area.....	10
› Alternative colour versions – negative version	
Background rules.....	11
› Minimum size	
Mute logo.....	12
› Misuses of the logo.....	13
› Multilingual logo.....	14
› Co-branding with the European institutions and CoR political groups.....	16

Graphic Line

› Main and secondary typography.....	17
› Alternative typography for Office Titles system and rules.....	18
› Graphic elements – white diamond shape.....	19
› Graphic elements – grid system.....	20
› Grid system – portrait format.....	21
› Grid system – landscape format.....	22
› Co-branding with partners and for events.....	23

Logo

Composition

The European Committee of the Regions logo is comprised of three connected elements: ❶ the continuous sound waves, ❷ the European Union flag and ❸ its name.

- ❶ It has been designed around the concept of continuous sound waves, which represents both sending and receiving of information, from grassroots Europe at the local and regional level to the heart of the European Union, with the CoR playing a central role.
- ❷ The CoR shares the same values and aspirations with the EU institutions, and the use of the EU flag strengthens the visual alignment with them.
- ❸ The third element is its name: European Committee of the Regions.

The CoR logo exists in positive and negative, in which there further exists CMYK, black and pantone versions, all of which are available in 4 different formats:

- › ai
- › eps
- › jpg
- › png

All these formats are available on the Visual Identity webpage <https://cor.europa.eu/en/visual-identity>

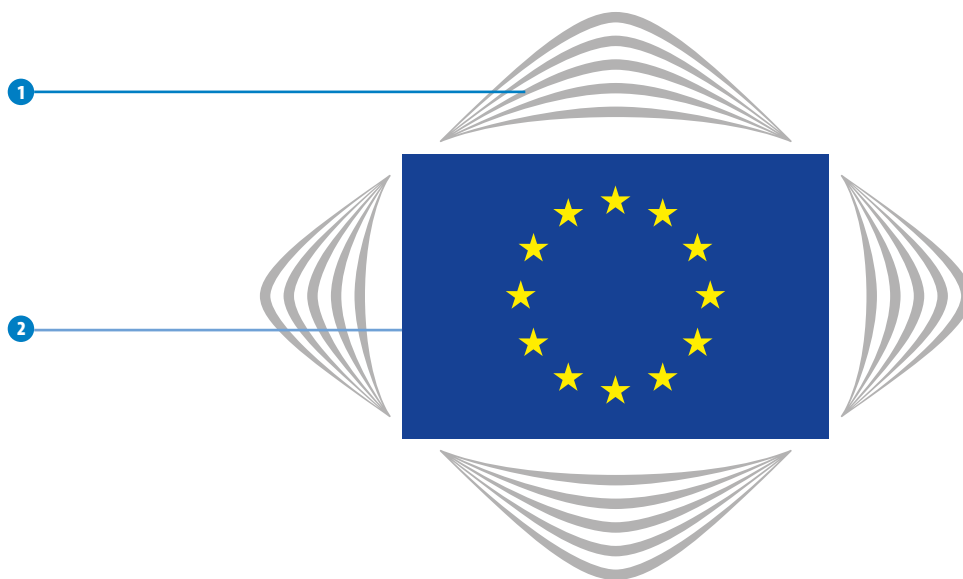

❸ European Committee of the Regions

Logo

Language versions

The logo has been adapted to the 24 official languages of the European Union. The language versions below appear in alphabetical order of the formal titles in their original written forms (according to the [ISO codes 639-1](#)).

For horizontal language versions or adaption to other languages, please contact visuals@cor.europa.eu



Европейски комитет
на регионите

BG



Comité Europeo
de las Regiones

ES



Evrópský výbor
regionů

CS



Det Europæiske
Regionsudvalg

DA



Europäischer Ausschuss
der Regionen

DE



Euroopa Regionide
Komitee

ET



Ευρωπαϊκή Επιτροπή
των Περιφερειών

EL



European Committee
of the Regions

EN



Comité européen
des régions

FR



Coiste Eorpach
na Régiún

GA



Europski
odbor regija

HR



Comitato europeo
delle regioni

IT



Eiropas Reģionu
komiteja

LV



Europos regionų
komitetas

LT



Régiók Európai
Bizottsága

HU



Kumitat Ewropew
tar-Regjuni

MT



Europees Comité
van de Regio's

NL



Europejski Komitet
Regionów

PL



Comité das Regiões
Europeu

PT



Comitetul European
al Regiunilor

RO



Európsky výbor
regiónov

SK



Evropski
odbor regij

SL



Euroopan alueiden
komitea

FI



Europeiska
regionkommittén

SV

Logo

Proportion

The European Union flag is the defining element on which the grid system is based. The wordmark is precisely positioned, centred with the flag.

In order to see the different elements as a whole and to achieve balance, it is mandatory to respect these alignment and positioning specifications.

The vertical format of the logo is the first choice to opt for.

The horizontal logo is a substitute of the standard logo which is vertical in cases when the applicability of the standard logo is constrained due to space or aesthetic reasons. The cases identified for the use of the horizontal logo can be backdrops or signposting of buildings.

STANDARD LOGO - VERTICAL

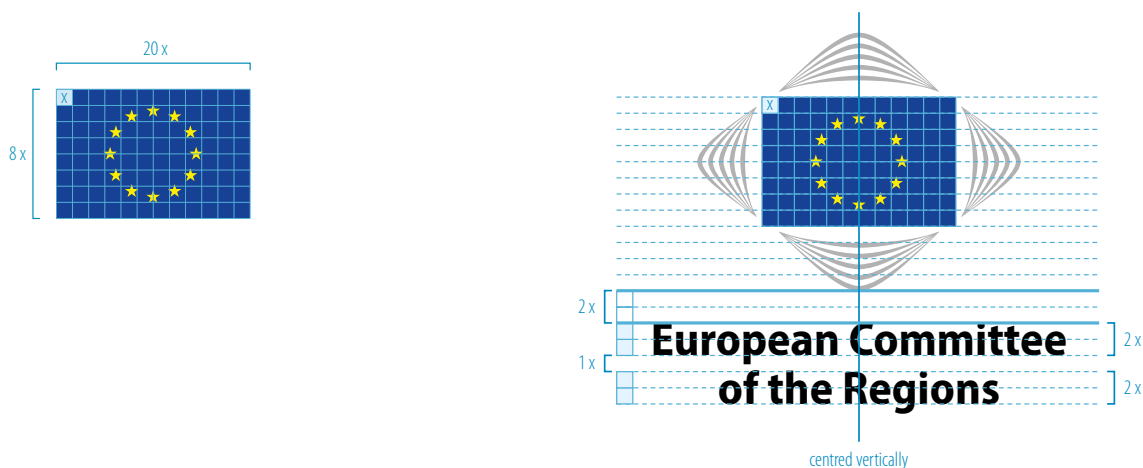

SUBSTITUTE OF THE STANDARD LOGO - HORIZONTAL

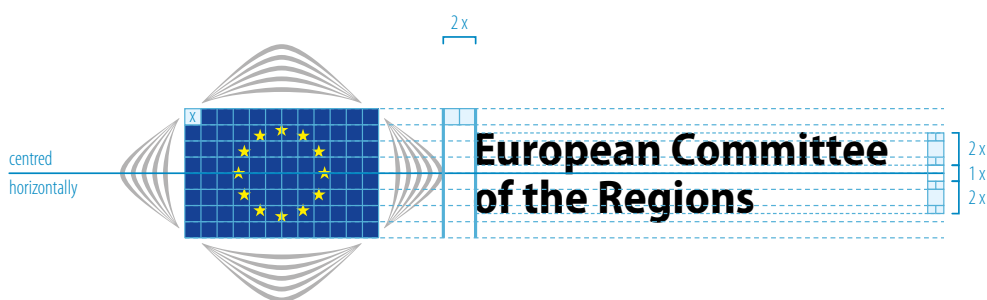

SUBSTITUTE OF THE STANDARD LOGO - HORIZONTAL / SMALL SIZE ONLY



Logo

Typography

Colour palette

Typography

The choice of typography is Myriad Pro, an OpenType® sans serif font.

It is clean and modern, fitting easily with the design of the visual aspect of the logo. It is also technically sound, in that it can be used for all of the official languages of the European Union as it supports a wide range of characters.

Colour palette

There are three main colours used as key elements in the design of this logotype. For consistency, please refer to the colours presented on this page. The colours which make up the CoR logo are:

- › Blue and yellow as the original colours of the EU flag
- › Black, used for the symbol at 40% and for the wordmark at 100%

Typography of the wordmark “European Committee of the Regions”:

Myriad Pro Bold SemiCondensed

ABCDEFGHIJKLMNOPQRSTUVWXYZ

abcdefghijklmnopqrstuvwxyz

0123456789



**European Committee
of the Regions**

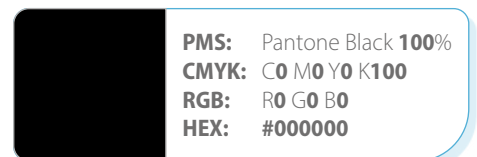
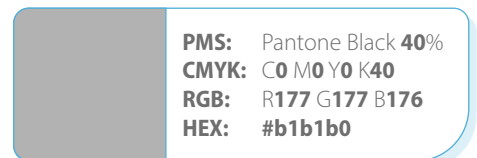
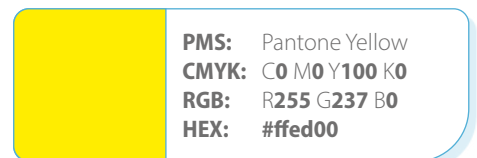

Logo

Clear Space area

A minimum clear space requirement has been established to ensure the integrity and clarity of the CoR logo. It is essential that it remains free of all graphics, taglines, identities, photography, and typography.

The clear space equals $4X$
($X=1/8$ of the height of the EU flag).

Always reduce or increase the logo proportionally and make sure that its original proportions are respected.

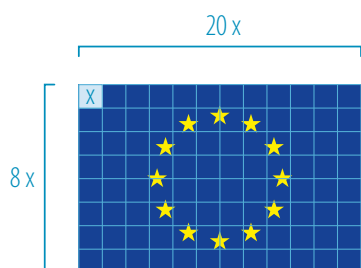

Logo

Alternative colour versions – negative version Background rules

Alternative colour versions - negative version

On dark backgrounds the logo needs to be inverted. In this version the logo keeps only the colours of the EU flag while the rest of the elements are pure white.

Around the EU flag a thin white line has been inserted to delimit the flag from the background.

In one colour printing the logo is converted to pure white only.

Background rules

When working on coloured backgrounds, determining which version of the logo to use is a decision based on common sense.

The goal is to have all the elements of the logo visible and the name of the institution clearly legible.



Full colour printing - CMYK



One colour printing - black



One colour printing - pantone

Full colour printing - CMYK

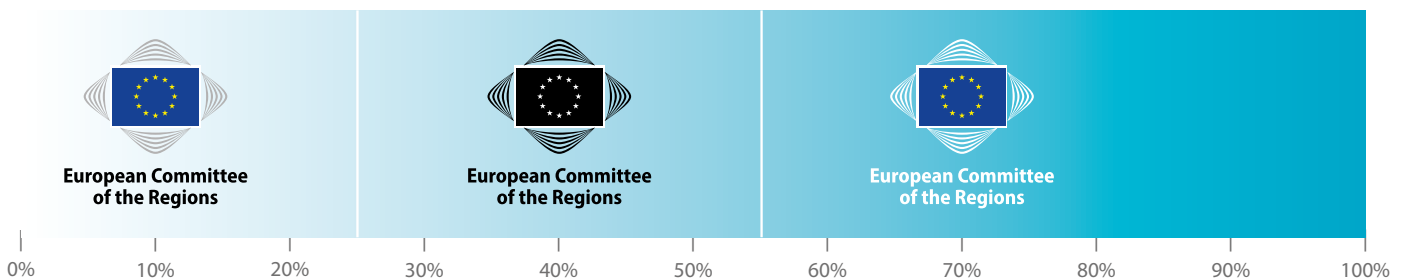

One colour printing - Black, Pantone Reflex Blue

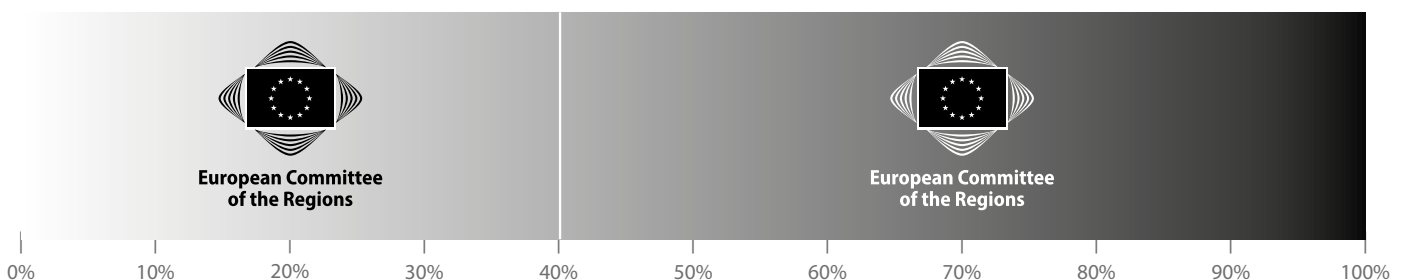

Logo

Minimum size

Mute logo

Minimum size

Minimum size refers to the smallest size at which the logo may be reproduced on a variety of products or supports such as pens.

This is to ensure its legibility. The minimum reproduction size of the standard logo is 10 mm in width in reference to the EU flag **1**. (Please refer to section “proportion” on page 8 to get information on the use of the substitute **2** of the standard logo).

However, in case the logo must be reproduced in a smaller size, it is recommended to use the logo horizontal with the wordmark justified on the EU flag’s height **3**. In this case, the minimum size of the logo is 10 mm in height.

Mute logo

For very special situations where the rules set up in these guidelines might not allow the use of the complete logo, an alternative mute logo has been developed. It comprises only the sound waves and the EU flag.

The mute logo can be used for situations where there is not enough space to use the complete logo or the name of the institution is already present.

1 STANDARD LOGO

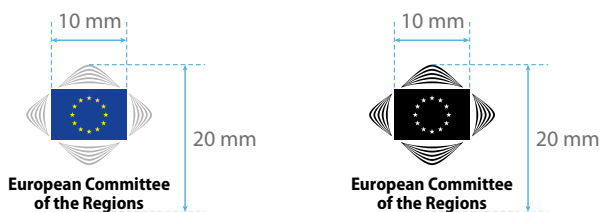

MUTE LOGO



2 SUBSTITUTE OF STANDARD LOGO



3 SUBSTITUTE OF STANDARD LOGO - SMALL SIZE



Logo

Misuses of the logo

The logo was designed with certain rules of proportion and with careful consideration regarding colours and

typeface. To preserve the integrity of the logo, modifying it in any way is not permitted.



DON'T DISTORT THE LOGO



DON'T CAPITALIZE THE TEXT



DON'T USE SPECIAL EFFECTS



DON'T CHANGE TEXT ALIGNMENT



DON'T CHANGE TEXT POSITION



DON'T CHANGE THE TYPEFACE



DON'T OUTLINE THE LOGO



DON'T CHANGE THE COLOURS



DON'T CHANGE PROPORTIONS



DON'T USE THE NEGATIVE VERSION WITHOUT THE WHITE BORDER AROUND THE FLAG

Logo

Multilingual logo

The European Committee of the Regions has also developed multilingual versions of its logo.

When dictated, a version with two languages can be used. In such cases, the languages would appear one on top

of the other as the third element of logo with the text in alphabetical order of the formal title in their original written forms (according to the [ISO codes 639-1](#)).

English / French bilingual version



European Committee of the Regions
Comité européen des régions

French / Dutch bilingual version



Comité européen des régions
Europees Comité van de Regio's

Logo

Multilingual logo

An exception applies for the bilingual logo that would be used exclusively on the exterior of all European Committee of the Regions' buildings. In this case, the texts would be

side by side in French and Dutch as according to Brussels regulations on exterior signage.

This version is not to be used in any other circumstance.

French / Dutch bilingual version for exceptional use (see above conditional usage)



**Comité européen
des régions**

**Europees Comité
van de Regio's**



Building Jacques Delors

© Bureau d'architecture Atelier Paul Noël sprl - Art & Build s.a.

Photo © European Union, 2017

Logo

Co-branding with the European institutions and CoR political groups

The different logotypes should always respect the same visual balance when used together with the European Committee of the Regions' logo.

If possible, align the different logotypes to the EU flag as shown on the illustration below.

The minimum space between logotypes is the same width of the EU flag.

For co-branding with CoR political groups logos, ensure that all logos have equal and balanced visual weight and align them with each other horizontally.

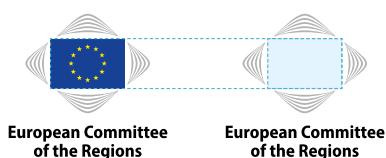

Graphic Line

Main and secondary typography

Main typography

Myriad Pro font family must be used for all the communication materials. It was chosen for its visual and technical characteristics.

Moreover, it covers the Latin, Cyrillic and Greek alphabets.

It comes in a wide variety of weights and widths providing generous creative palette to use across all communication supports.

Secondary typography

The serif Minion Pro font used in association with the sans serif Myriad Pro font will bring contrast and rhythm to the layouts and provide greater legibility. This typography will only be used on the inside pages of publications.

MAIN TYPOGRAPHY

Myriad Pro light / light italic

ABCDEFGHIJKLMNOPQRSTUVWXYZ
abcdefghijklmnopqrstuvwxyz

ABCDEFGHIJKLMNOPQRSTUVWXYZ
abcdefghijklmnopqrstuvwxyz

Myriad Pro regular / regular italic

ABCDEFGHIJKLMNOPQRSTUVWXYZ
abcdefghijklmnopqrstuvwxyz

ABCDEFGHIJKLMNOPQRSTUVWXYZ
abcdefghijklmnopqrstuvwxyz

Myriad Pro semibold / semibold italic

ABCDEFGHIJKLMNOPQRSTUVWXYZ
abcdefghijklmnopqrstuvwxyz

ABCDEFGHIJKLMNOPQRSTUVWXYZ
abcdefghijklmnopqrstuvwxyz

Myriad Pro bold / bold italic

ABCDEFGHIJKLMNOPQRSTUVWXYZ
abcdefghijklmnopqrstuvwxyz

ABCDEFGHIJKLMNOPQRSTUVWXYZ
abcdefghijklmnopqrstuvwxyz

SECONDARY TYPOGRAPHY

Minion Pro regular / regular italic

ABCDEFGHIJKLMNOPQRSTUVWXYZ
abcdefghijklmnopqrstuvwxyz

ABCDEFGHIJKLMNOPQRSTUVWXYZ
abcdefghijklmnopqrstuvwxyz

Minion Pro medium / medium italic

ABCDEFGHIJKLMNOPQRSTUVWXYZ
abcdefghijklmnopqrstuvwxyz

ABCDEFGHIJKLMNOPQRSTUVWXYZ
abcdefghijklmnopqrstuvwxyz

Minion Pro semibold / semibold italic

ABCDEFGHIJKLMNOPQRSTUVWXYZ
abcdefghijklmnopqrstuvwxyz

ABCDEFGHIJKLMNOPQRSTUVWXYZ
abcdefghijklmnopqrstuvwxyz

Minion Pro bold / bold italic

ABCDEFGHIJKLMNOPQRSTUVWXYZ
abcdefghijklmnopqrstuvwxyz

ABCDEFGHIJKLMNOPQRSTUVWXYZ
abcdefghijklmnopqrstuvwxyz

Graphic Line

Alternative typography for Office Titles system and rules

Alternative typography for Office/system fonts

Arial and Times fonts are used for office applications (e-mail, Word documents, Powerpoint presentations), HTML content or other applications. It will be used as a substitute for those cases where the Myriad Pro or the Minion Pro cannot be implemented.

Titles system and rules

The Myriad Pro Semibold Semicondensed is the typography selected for titles on covers, posters, banners among others. Together with the white diamond shape placed behind the logo (see facing page), this font reflects another common visual element on all publications of the European Committee of the Regions.

The contrast of size between the headline and the subtitle follows a ratio of 50%. It is important for the visual effect and distinctiveness. It can be achieved rather easily using the following method:

"2" is the reference figure used to divide or multiply the size of the text to achieve the proper contrast between the headline and the subtitle.

ALTERNATIVE TYPOGRAPHY FOR OFFICE/SYSTEM FONTS

Arial regular / italic

ABCDEFGHIJKLMNOPQRSTUVWXYZ
abcdefghijklmnopqrstuvwxyz
ABCDEFGHIJKLMNOPQRSTUVWXYZ
abcdefghijklmnopqrstuvwxyz

Arial bold / bold italic

ABCDEFGHIJKLMNOPQRSTUVWXYZ
abcdefghijklmnopqrstuvwxyz
ABCDEFGHIJKLMNOPQRSTUVWXYZ
abcdefghijklmnopqrstuvwxyz

Times New Roman regular / italic

ABCDEFGHIJKLMNOPQRSTUVWXYZ
abcdefghijklmnopqrstuvwxyz
ABCDEFGHIJKLMNOPQRSTUVWXYZ
abcdefghijklmnopqrstuvwxyz

Times New Roman bold / bold italic

ABCDEFGHIJKLMNOPQRSTUVWXYZ
abcdefghijklmnopqrstuvwxyz
ABCDEFGHIJKLMNOPQRSTUVWXYZ
abcdefghijklmnopqrstuvwxyz

TITLES SYSTEM AND RULES

Headline (60pts)

divided by 2 =

Subtitle (30pts)

Graphic Line

Graphic elements – white diamond shape

White diamond shape is established in five steps:

- 1 in Adobe Illustrator, a square of 100 mm x 100 mm is drawn
- 2 this square is rotated 45 degrees to obtain a diamond shape
- 3 the new dimensions of the diamond shape are changed to:
width = 120 mm and height = 100 mm
in order to elongate the shape.
- 4 The corner  values are changed to:
top and bottom angles = 10 mm
left and right angles = 8,5 mm.
The white diamond shape is set up.
- 5 The width of the white diamond shape is equal to 10x the width in reference to the EU flag of the European Committee of the Regions logo.

This shape can also be used as a decoration element on covers and inside pages.

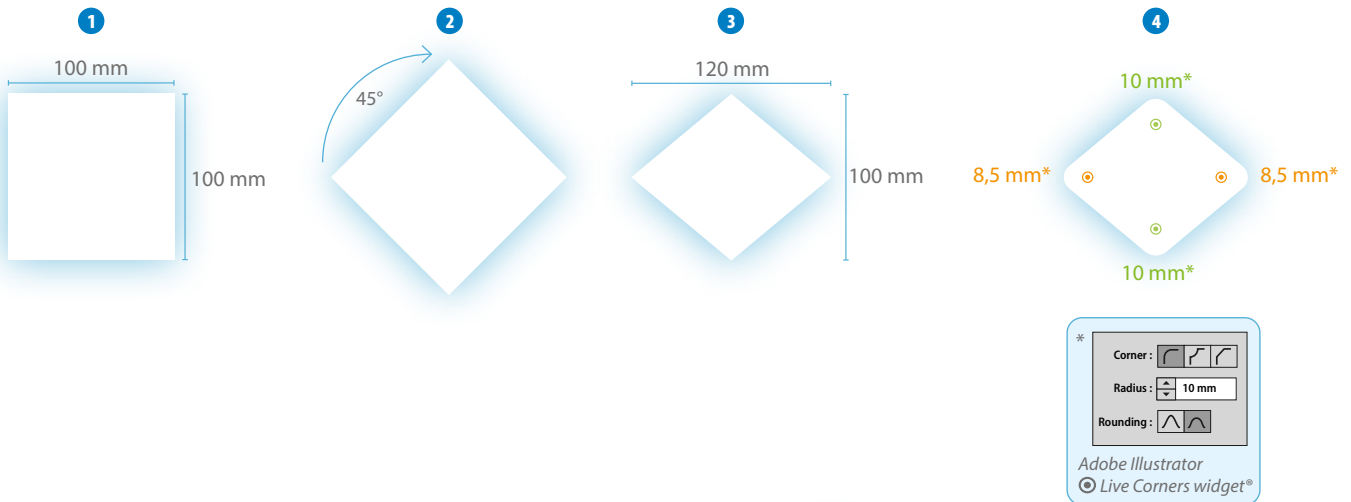

10x

Graphic Line

Graphic elements – grid system

The size of the logo is proportional to the width of the publication.

① x = the width in reference to the EU flag of the European Committee of the Regions logo.

The table below specifies the proportion of the European Committee of the Regions logo on standard formats.

The logo of the European Committee of the Regions is always placed on a proportional white diamond shape. (Please refer to section *Graphic elements - white diamond shape* on page 19 to get information how to build this specific shape).

The white diamond shape is the main visual element that defines the graphic line of the European Committee of the Regions together with the title system defined on page 18.

While creating a dedicated and recognisable branding image for the publications of the European Committee of the Regions, this shape enhances the logo by bringing a clear area around it and ensuring its visibility.

① **Example:**
A4 layout

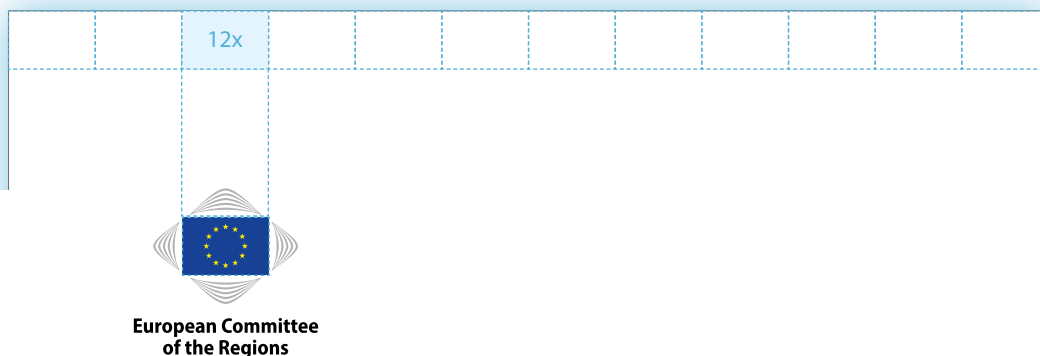

	VERTICAL LAYOUT							HORIZONTAL LAYOUT								
	A6	A5	A4	A3	A2	A1	A0	80x200cm	A6	A5	A4	A3	A2	A1	A0	300x100cm
8x								◆								
10x	◆															
11x		◆														
12x			◆	◆	◆	◆	◆									
15x								◆								
16x									◆							
17x										◆	◆	◆	◆	◆		
21x																◆

Graphic Line

Grid system – portrait format

1 The size of the European Committee of the Regions logo is proportional to the width of the publication. Please refer to the *table* on page 20 to select the correct proportion.

If the format is not available in the table, the closest format of the table will be used as a base. It will be reduced or increased proportionally based on the width for vertical layout, or the height for horizontal layout.

2 Once adapted to the correct proportion, the logo is placed in the top left corner of the layout based on following alignment rules:

Top alignment : the EU flag of the logo is aligned on 1x the width of the EU flag.

Left alignment : the EU flag of the logo is aligned on 2x the height of the EU flag.

3 The white diamond shape* is centred vertically on the logo and aligned on 3x the height of the EU flag.

*Please refer to section "Graphic elements - white diamond shape" on page 19 for information on how to build this specific shape.

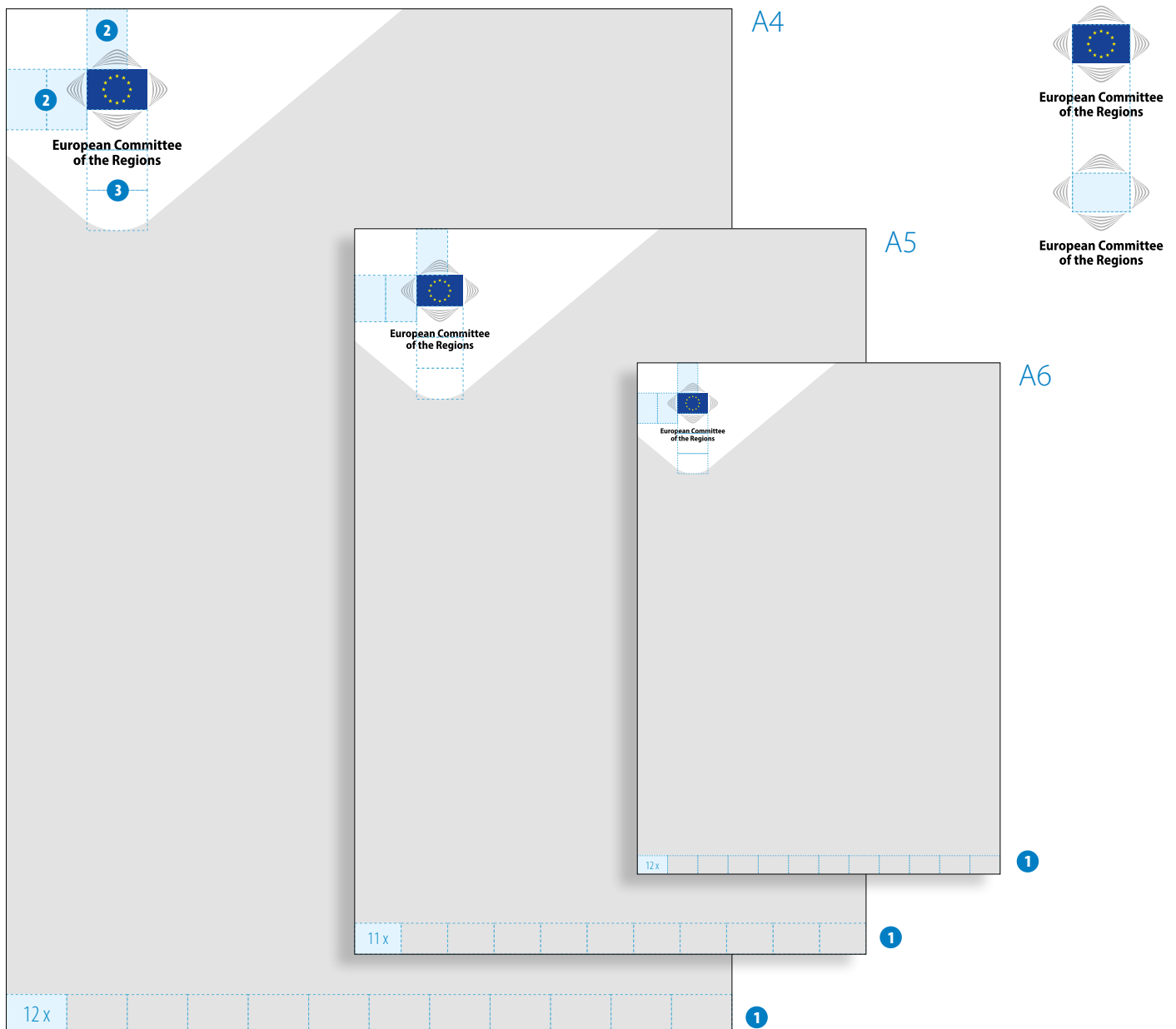

Graphic Line

Grid system – landscape format

The grid system of the portrait format applies the same for the landscape format.

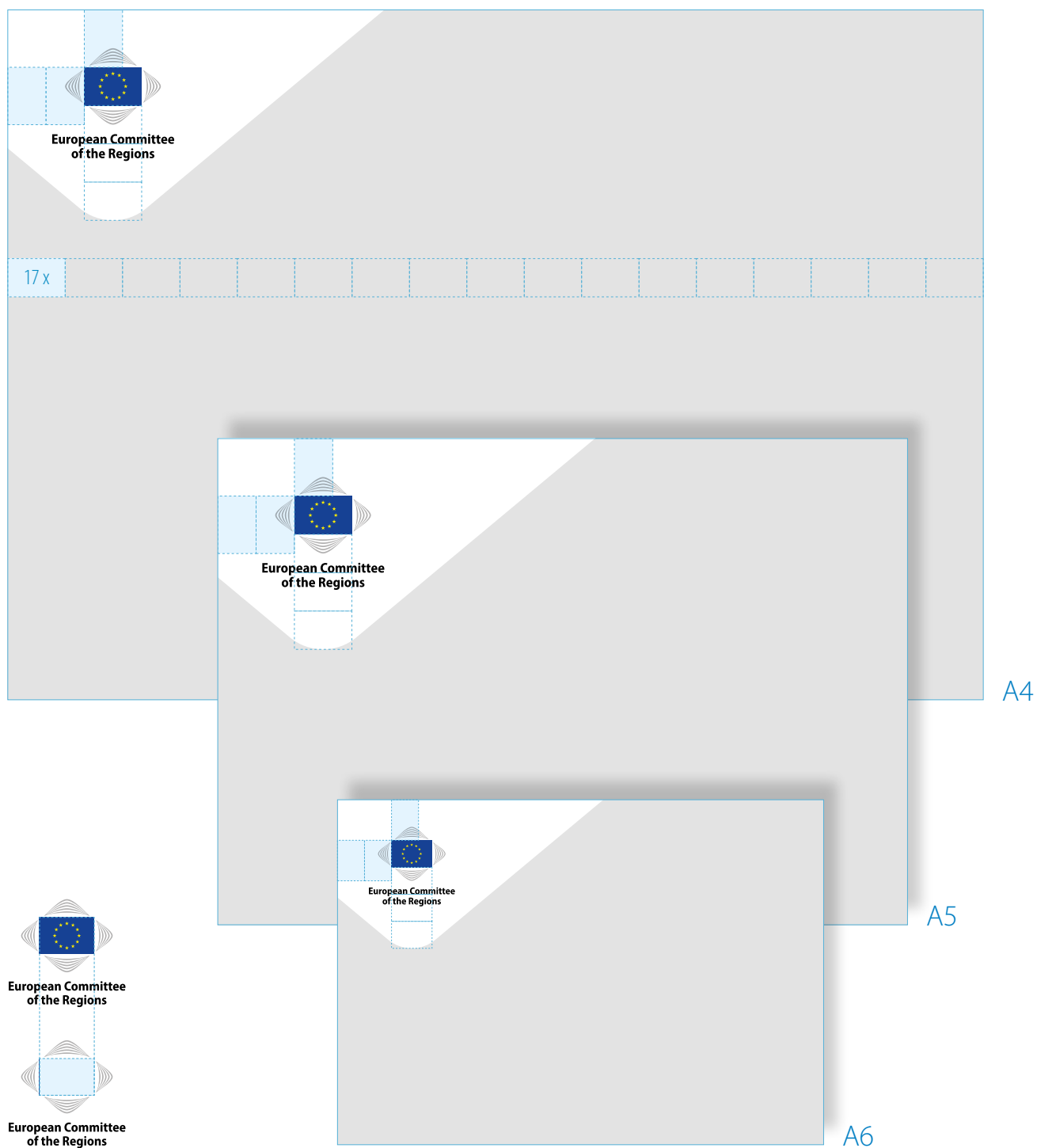

Graphic Line

Co-branding with partners and for events

When a publication is co-produced, the logos of the co-authors will be displayed on the cover.

There are 3 ways to display the co-branding:

If the publication is produced by the European Committee of the Regions, the logo will be placed on the publication and the other logos will be placed next to it **1**, or on a white stripe at the bottom of the layout **2**.

If the publication is produced by the European Committee of the Regions, but a dedicated logo has been created for the event (such as Summits, European Week of Regions and Cities, EuroPCom...), the logo of the European Committee of the Regions will be placed at the bottom of the page with the logos of the other organisers **3**.

1



2

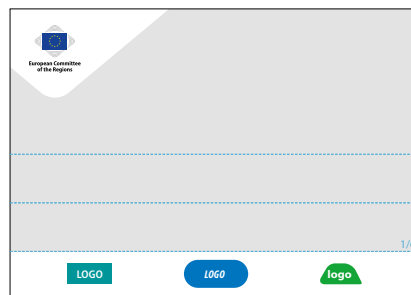
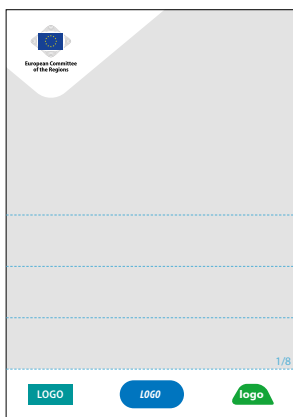

3

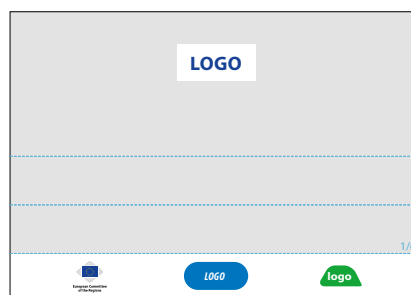
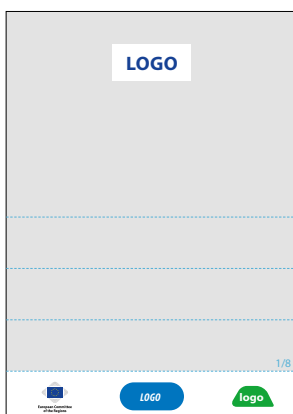

CHAPTER 2

Printed media

Stationery

› Letterhead.....	26
› Business card.....	27
› Compliment card.....	28
› Invitation.....	29
› Envelopes.....	30
› Electronic signature.....	32
› Document folder.....	33
› Power Point slides.....	34
› Notepads.....	36
› Promotional items.....	37

CoR Publications

› Brochure – grid system for cover.....	38
› Brochure – examples of covers and backcovers.....	39
› Brochure – grid system for interior page layout.....	42
› Brochure – examples of interior page layouts.....	43
› Leaflet – grid system for cover.....	45
› Leaflet – examples of covers and backcovers.....	46
› Poster – grid system.....	48
› Poster – examples.....	49
› Signpost – grid system.....	50
› Signpost – examples.....	51
› Badges – grid system and examples.....	52
› Roll ups and stands.....	53
› Infographics – grid system.....	54
› Infographics – examples.....	55
› Factsheet – grid system.....	56
› Factsheet – examples.....	57
› CoR identity on political groups publications.....	58

Stationery

Letterhead

210 x 297 mm (A4)

1x 2x 1/12 4x 5x 6x 7x 8x 9x 10x 11x 12x

15 mm

50 mm



**European Committee
of the Regions**

Arial regular, 10pt,
leading 12pt,
black 100%

Arial bold, 12pt,
leading 14.4pt,
black 100%

Title
Subtitle

Arial regular, 10pt,
leading 12pt,
black 100%

Ucient as raeperi onessinciis di soluptis aligenditas ipicaest moluptatur? Et apit laceria volupta tatusant vitatem aut mod que voluptate volesti omnis imoluptatum sinveribus dolupta nient, ommost aute cus exeribu scilliquasi nonsedit vella nobit ut magnis digenis et harcipsape porepel ectur, utem laborrorat volorem sequate laborum faccae cus mos eatquo molecum quia corempe rovidi te volum as ditat.

Luptiumqui optatur, conse dundebit ut ero iuriore roritam fugiandesed que namusa qui dendandicidi aut doluptas et, sed quae volore sin pereperia sum illest as exerent doloratur, ad eatianti qui blaborero tent provid que illentior alibus autas untio. Odipsum solupta del ius, ne conseque venimi, vendaecerrum volupta tempore qui arcite voluptatur?

Dellupt atust, ipsam inumendia cum et eatia vendit voloriam sin consequo eicae pro cusa quas qui ilis era ducid et duntur? Qui ut evelis asperum si nem remolup tatemos ea non est aut laut aci consed mo ese pa quam ut rectae derspit quiatquam nusapiet ist aut quis aliquae cerchillor aut fugiamus dundendam quateseque ne nus dolut volupid ucilitem licia venis et vendiorum iniasperi doluptatem cones et quam qui as reritius sitatatur? Aliatem qui re nullaboreius mod quae vollum qui nosapel eserum apit harum aciis voluptatem que eium qui berorendam vento dolorios volupti cum aut la et eium velit expla etur?

Fernamus aut veria quunt aut aut et experum idebit doluptatem. Nam, id mint est etus ex ent.

Dus, to cum nat arum doluptionem inctem volupta ersperion prae non consed quam evelentis aut rature iunt aut quia necearum labo. Essed quidest et vid milicium ium quiam, adis adipsanis explab invenih iliquat occupa tianditae officia doluptas nonseque non nus dit il il mod et lab illitibus ducil idit estiati numqui te volenis cipsant urerupid quo et aut doloris quid qui nonseque ra dolor aut occat rem de porepud antior a cus expliame excess, ut alignam qui sequo officatem quo eossinus remolore volut ommos esequia poreper umquis eicid unt, ut es magnatur sum corat perati occupet expla nonsend ipsaero voluptatur sa eum ut et eos venihilit et ad unt.

Uptat que ea quosandandis maioressi doluptin numenis nataquam invellent quo od et ut voluptat et omnihillaut aperest, a conseni tatiassit qui nobit quat.

Edipsum, quas qui recto cus vollabo reperios exeria nonsed ute debis et acest officae et quundae sequam dia volorup tatur, natquamus es de mintotatem erit, tem imolupt aspelitati totam rerati qui aut liquam numquo quam est, esedi omnimil imus etur mil erundandam, soluptaquam soluptur arum quid quid ullis mos velique non nonecae puditatur, officab oremquiducia nestor aruptatemque laborru mquatur, essit, ommoloritiat untendantis dionse eatinve recuptatio essume vendunditia il iligendempor autatibus eatquiae pellabo rerruntis repedipis iducillis dolorem porrovi descisi consequis natur? As none-scius et entius ea volupta epeliquid modia venis deruntist aut doluptas et optiam intur sed et laboria versperiam eum aut doluptatur a as ipsuntio volorestia nones ant aspe sa nos magna gnimin et ratibus volorrovita volutatio nonem illabor epellora sit quidunt officte occatit ma estiam re rehendi stibus.

Uda sunt. Onest officte pos as ut equam eicia vit quo eniscipsa doluptaque ipsam, nonem in con restorporum, solorep erferio eossit voluptas aut et occusa nam, optatib erferumquia quasi nimagnis dolorerio ius.

Ficae re idellac cupurtiorum endae aut ut aspient emposte ceatemque expelendel et estrum exped essi aut accaborro omnimetum harchit, aut qui ationsectet, odissitiis est quas doluptaectus assita porest quat.

Ullupta quamus nestibus doloris doluptin con perisque millabo rerciatu estis ex et, volore disita dolorecatur auta velitio. Sumqui omnis volorporia voluptae volut volupta dunt liquam dus mil in con enti conet hic temporia volut ut quo tempor simus consed mi, omnis que prem idunt.

Simperfero veni non cus etur accusaetae omnis sequis eaque et volorporpos dit quibus enimolupta perae nectotatae niet quis sus.

20 mm

10 mm

20 mm

20 mm

Rue Belliard/Belliardstraat 101 | 1040 Bruxelles/Brussel | BELGIQUE/BELGIË | Tel. +32.22822211
www.cor.europa.eu |  /european.committee.of.the.regions |  /european-committee-of-the-regions |  @EU_regions_cities |  @EU_CoR

Times New Roman regular,
10pt, leading 12pt,
black 100%

social media icons:
2.5 mm

Myriad Pro
light semicondensed, 8.5pt,
leading 11.5pt, black 100%

Stationery

Business card

55 x 85 mm

Dual language versions are available.
Please indicate on the order form a second language along with the default language (English or French).

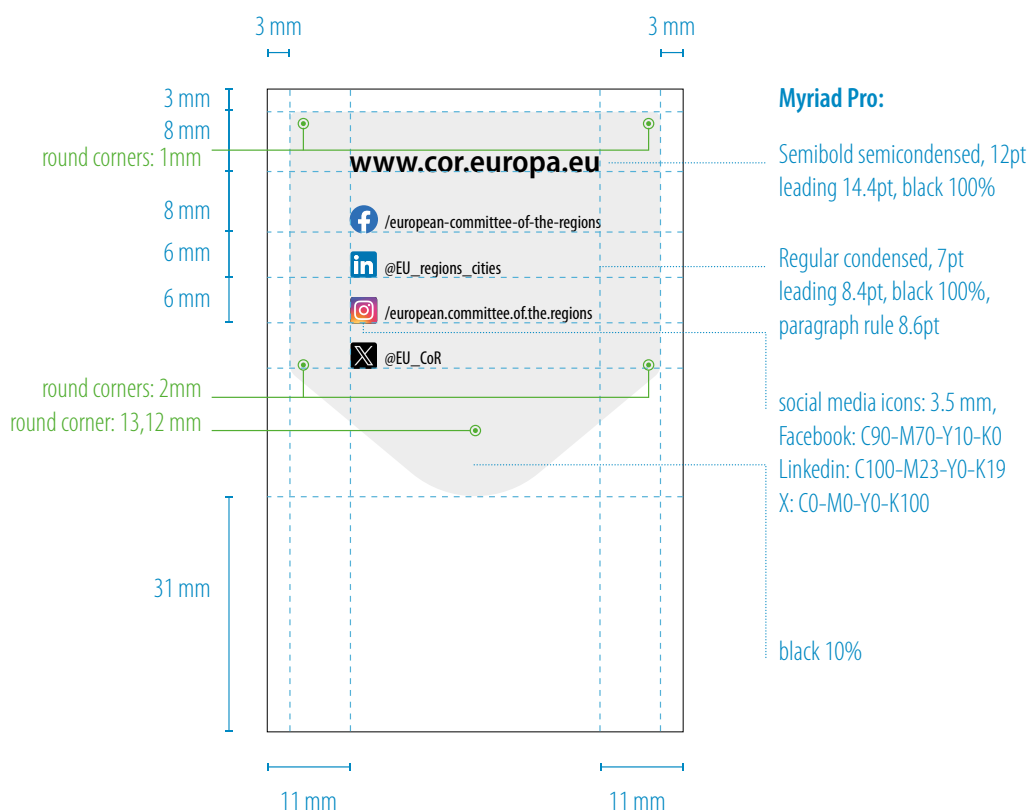
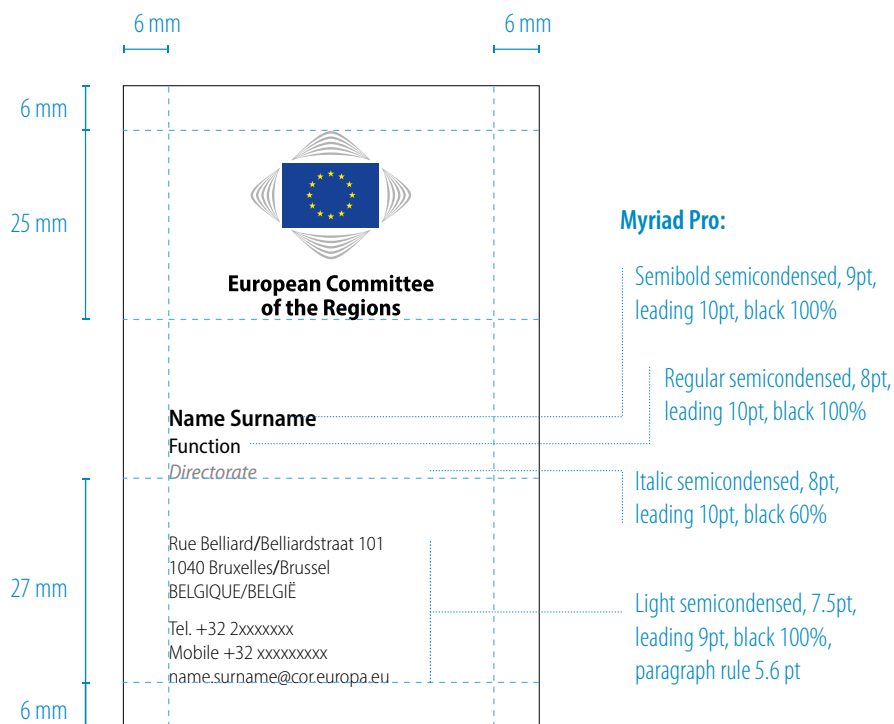

Stationery

Compliment card

210 x 105 mm

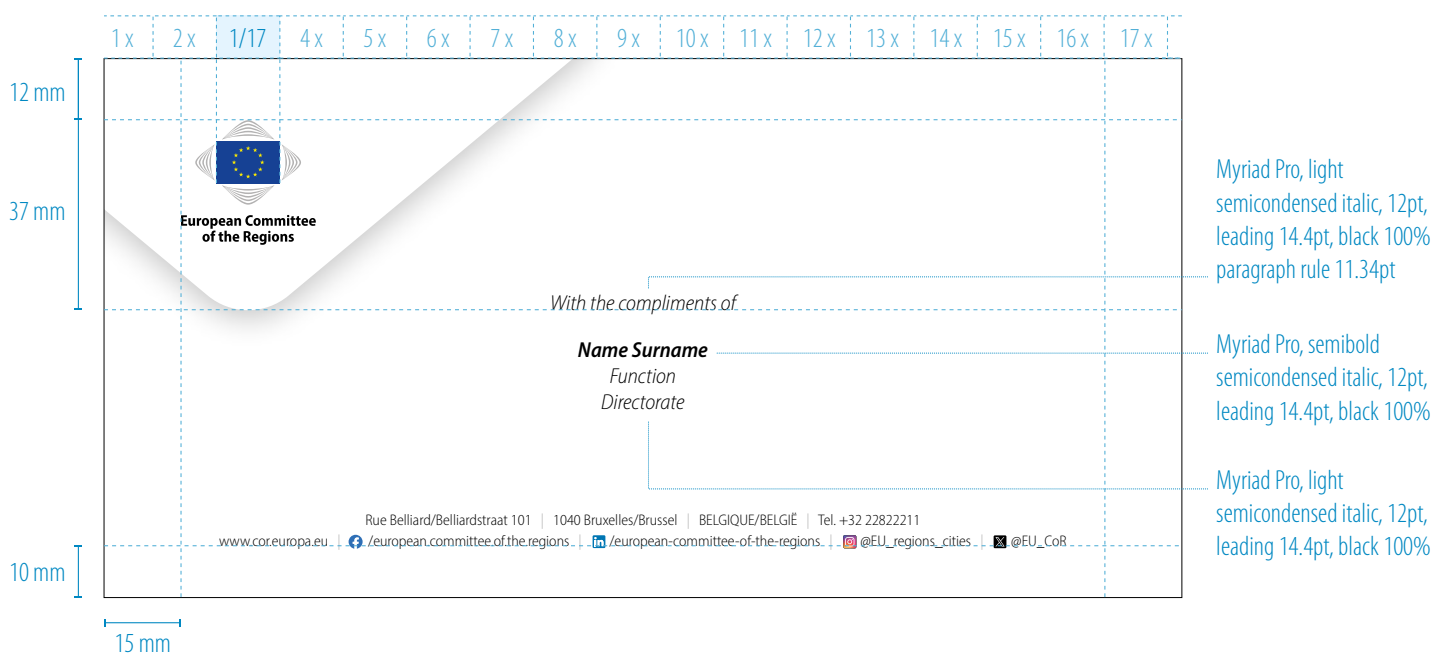
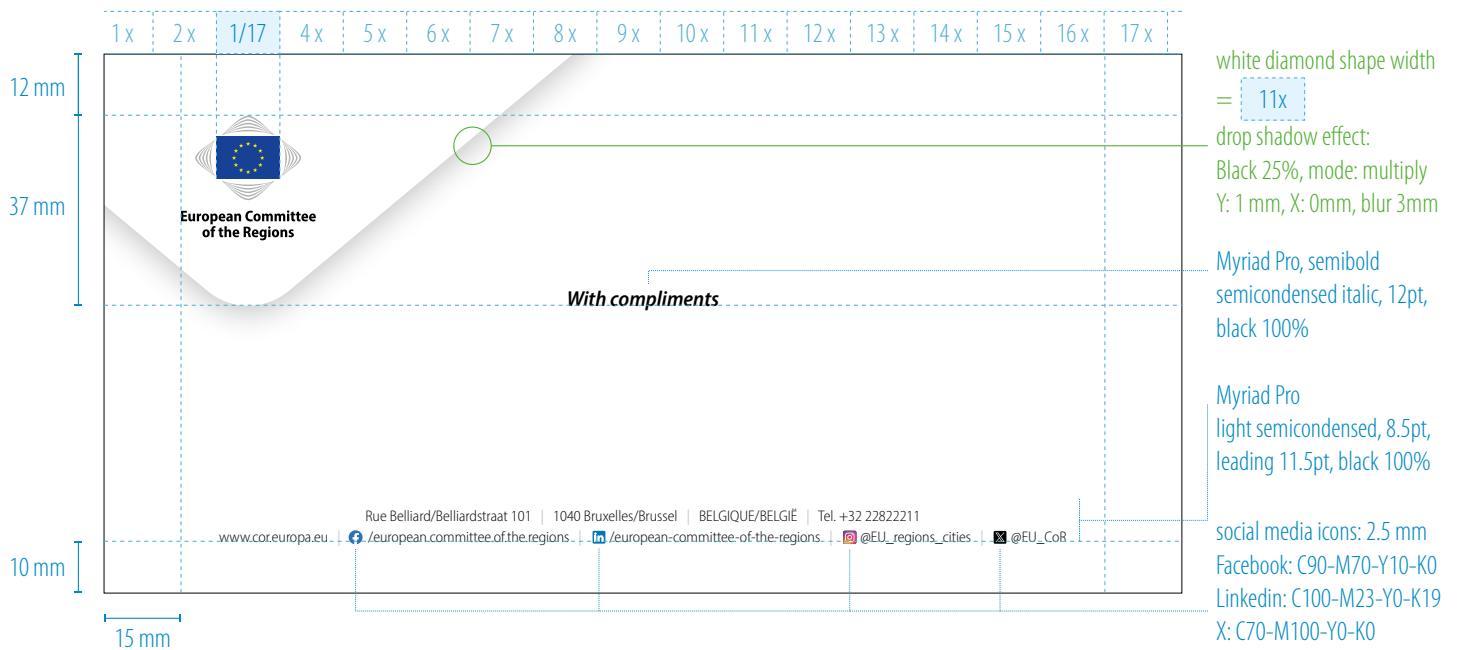

Stationery

Invitation

210 x 105 mm

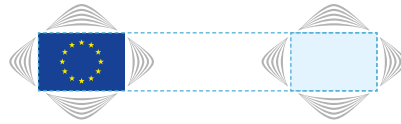

European Committee of the Regions

European Committee of the Regions

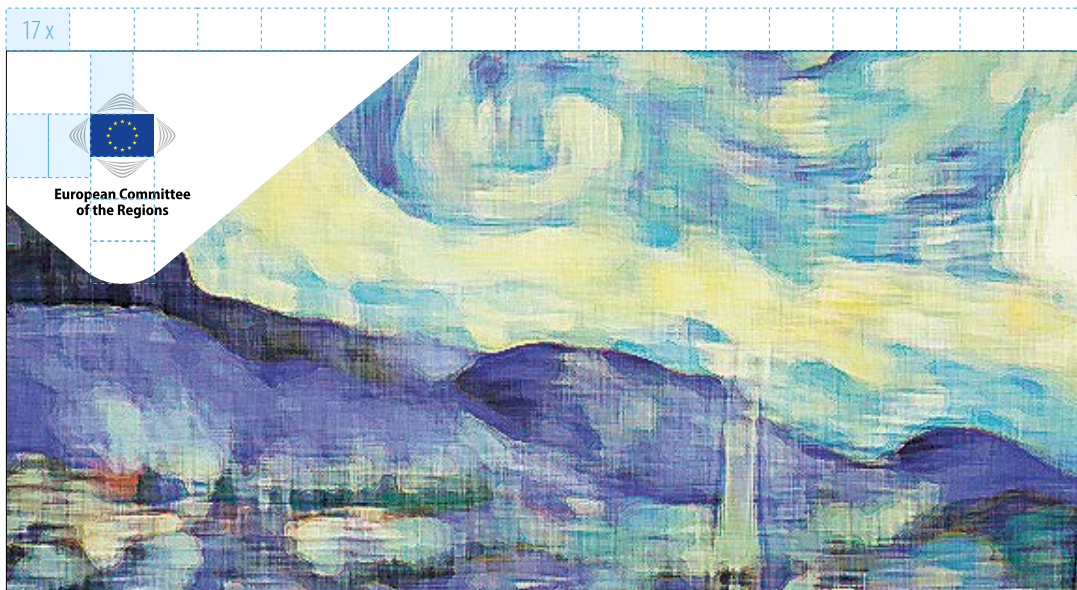

	1x	2x	3x	4x	5x	6x	7x	8x	1/17	10x	11x	12x	13x	14x	15x	16x	17x	
--	----	----	----	----	----	----	----	----	------	-----	-----	-----	-----	-----	-----	-----	-----	--

10 mm

35 mm

7 mm

10 mm 5 mm

5 mm 10 mm

diamond shapes width = 10x

Myriad Pro, regular, 10pt, leading 12pt, black 100%

Myriad Pro, semibold semicondensed, 13pt, black 100%

Myriad Pro, italic, 10pt, black 100%

Myriad Pro light semicondensed, 8.5pt, leading 11.5pt, black 100%

European Committee of the Regions

Ecto dolupta turio. Soloruptas consequunt lit hicit as aut re corum quam, aboreris eniscil molendi demped molupidel iuntoriorese nim hilit, qui nim acerum reius, eum et dolo qui apid ullupieniet aut quia si bersperovid.

Name Surname

title

Would like to invite you to consequunt lit hicit as aut re corum quam, aboreris eniscil molendi demped iuntoriorese, on the nim hilit, qui nim acerum reius, eum et dolo qui apid ullupieniet aut quia, at the address...

Rue Belliard/Belliardstraat.101. | 1040.Bruxelles/Brussel. | BELGIQUE/BELGIË. | www.core.europa.eu. | RSVP for date at emailaddress@core.europa.eu. | +32 2xxxxxx

Stationery

Envelopes

- ❶ 229 x 114 mm
- ❷ 229 x 169 mm

❶

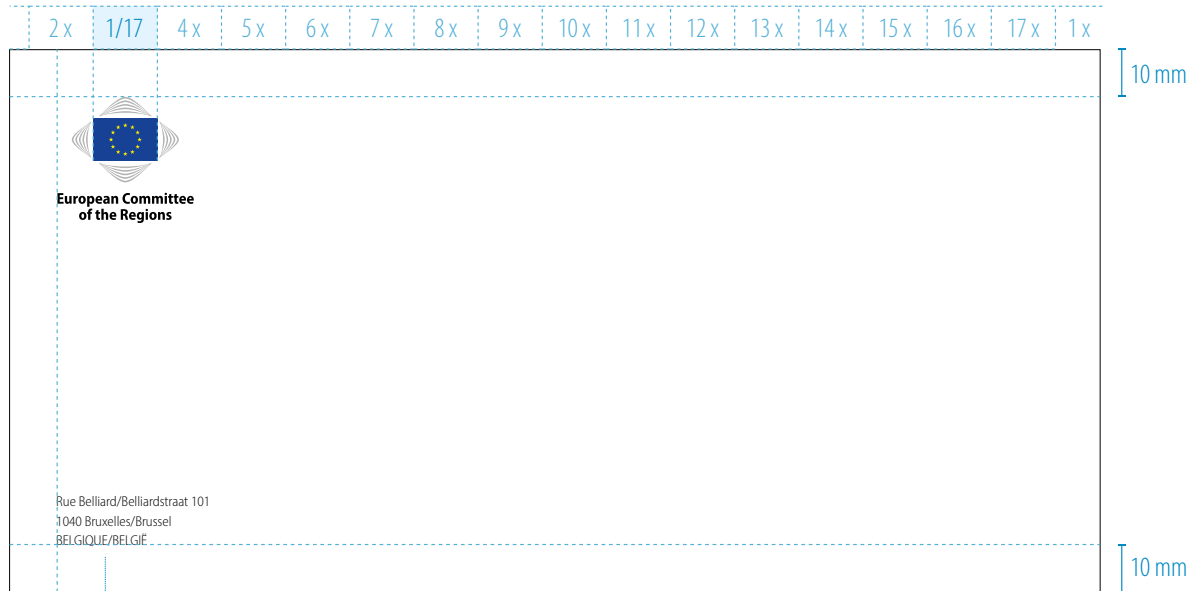

10 mm

Myriad Pro
light semicondensed, 8.5pt,
leading 11.5pt, black 100%

❷



10 mm

Myriad Pro
light semicondensed, 8.5pt,
leading 11.5pt, black 100%

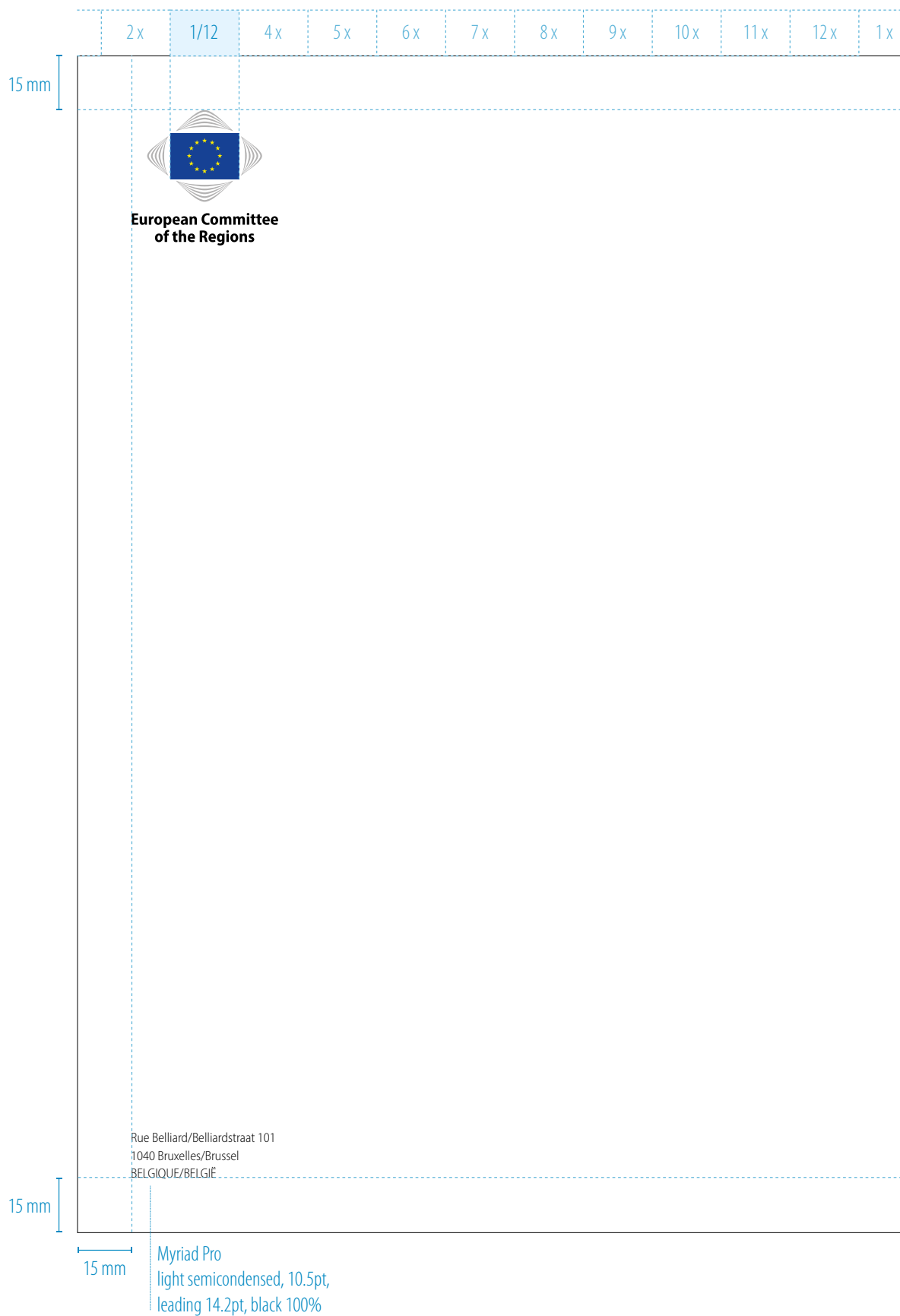

Stationery

Electronic signature

Good morning,

Ucient as raeperei onessinciis di soluptis aligenditas ipicaest moluptatur? Et apit laceria volupta tatusant vitatem aut mod que voluptate volesti omnis imoluptatium sinveribus dolupta nient, ommost aute cus exeribu scilliquasi nonsedit vella nobit ut magnis digenis et harcipsape porepel ectur, utem laborrorat volorem sequate laborum faccae cus mos eatquo molecum quia corempe rovidi te volum as ditat.

Luptiumqui optatur, conse dundebit ut ero iuriore roritam fugiandesed que namusa qui dendandicidi aut doluptas et, sed quae volore sin pereperia sum illest as exerent doloratur, ad eatianti qui blaborero tent provid que illentior alibus autas untio. Odipsum solupta del ius, ne consequer venimi, vendaecerrum volupta tempore qui arcite voluptatur?

Kind regards,



**European Committee
of the Regions**

Name Surname
Title/Function
Service, unit/Directorate
JDE xxxx | Tel. +32 2282xxxx | Mobile +32 xxxxxxxxx

Rue Belliard/Belliardstraat 101 | B-1040 Bruxelles/Brussel
www.cor.europa.eu
Follow us



Arial bold, 9pt
leading auto, HEX #000000

Arial regular, 8pt
leading auto, HEX #000000

Arial regular italic, 8pt
leading auto, HEX #585857

Arial regular, 8pt
leading auto, HEX #000000

CoR logo
76 pixels height

social media icons 11 x 11 pixels
HEX #474746

Stationery

Power Point slides

1920 x 1080 px (16:9)

Cover slide

16 x



European Committee of the Regions

Title of presentation

Subtitle of presentation

diamond shape, HEX #2c4390

Arial bold, 50pt leading auto, white

Arial bold, 25pt (= ½ Title) leading auto, white

blue background, HEX #313083

The cover slide features a dark blue background with a pattern of overlapping diamond shapes in a lighter blue shade. The European Committee of the Regions logo is positioned in the top left corner. The main title and subtitle are centered in white text. A grid of 16 columns is visible at the top of the slide.

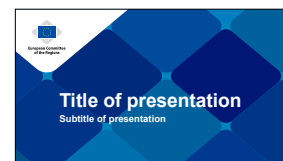
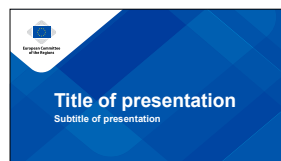

Content slide

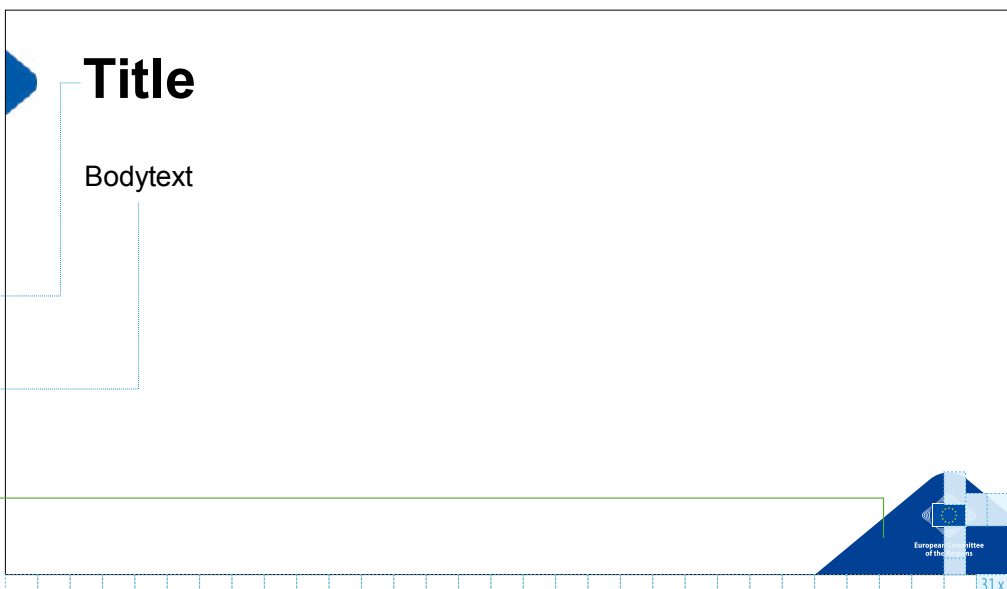

Title

Bodytext

Arial bold, 40pt leading auto, black

Arial, 20pt leading auto, black

dark blue diamond shape, HEX #2c4390

31 x

The content slide has a white background with a dark blue diamond shape in the top left corner. The title and body text are positioned to the right of this shape. The European Committee of the Regions logo is in the bottom right corner. A grid of 31 columns is visible at the bottom of the slide.



Stationery

Power Point slides

Chapter slide

Arial bold, 50pt
leading auto, white

Arial bold, 25pt (= ½ Title)
leading auto, white

blue background,
HEX #005BA8

Chapter title
Introduction text

Additional slides

Merci Obrigado Vã multumim
Děkujeme! Hartelijk dank **Gracias** Tak
Hvala Благодарим Ви Paldies! Ačiū
Kiitos **Thank you** Grazzi
Σας ευχαριστούμε Hvala Ďakujem
Köszönöm! Aitäh **Vielen Dank**
Grazie Go raibh maith agaibh Dziękujemy!

European Committee of the Regions

www.cor.europa.eu

European Committee of the Regions

eu_regions_cities

EU_CoR

Credits and re-use policy

Slide x © EU, artist 1, stock.adobe.com
Slide xx © EU, artist 2, stock.adobe.com
Slide xxx © EU

© European Union, year

Unless otherwise noted, the reuse of this document is authorised under a Creative Commons Attribution 4.0 International (CC BY 4.0) licence (<https://creativecommons.org/licenses/by/4.0/>). This means that reuse is allowed provided appropriate credit is given and any changes are indicated.

For any use or reproduction of elements that are not owned by the European Union, permission may need to be sought directly from the respective copyright holders. Accordingly, you are required to clear additional rights if a specific content includes third-party works. Where permission is obtained, such permission shall cancel and replace the above-mentioned general permission and shall clearly indicate any restrictions on use.

text HEX #254993

blue background,
HEX #BDDCF4

Chapter title
Introduction text

text white

blue background,
HEX #29386F

Chapter title
Introduction text

text and
blue background
HEX #005BA8

Chapter title
Introduction text

text HEX #254993

blue background,
HEX #BDDCF4

Chapter title
Introduction text

text and
blue background
HEX #29386F

Chapter title
Introduction text

Stationery

Notepads

148 x 210 mm (A5)

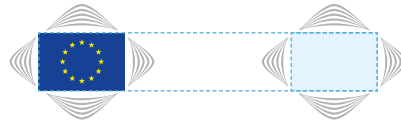

European Committee of the Regions

European Committee of the Regions

11x

European Committee of the Regions

Rue Belliard/Belliardstraat 101 | 1040 Bruxelles/Brussel | BELGIQUE/BELGIË
Tel. +32 22822211 | www.cor.europa.eu | /european.committee.of.the.regions
 /european-committee-of-the-regions | @EU_regions_cities | @EU_CoR

weight 0,4pt
space between lines: 7mm
dash 0,025 - gap 1,4

Myriad Pro
light semicondensed, 8,5pt,
leading 11.5pt, black 100%

social media icons: 2.5 mm,
black 100%

10 mm

10 mm

10 mm

Stationery

Promotional items

USB key



Bags



Lanyard



Pen

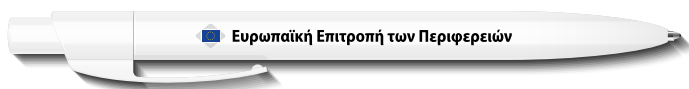

T-shirt



Umbrellas



CoR Publications

Brochure – grid system for cover

210 x 297 mm (A4)

The following system applies to the creation of covers and backcovers for European Committee of the Regions' brochures.

Please refer to the *grid system of the graphic line* on pages 20, 21 and 22 to find the proportion of the

European Committee of the Regions logo related to the format of the brochure, and on page 19 for information on *how to build the diamond shape* and to define its *proportion and placement behind the logo*.

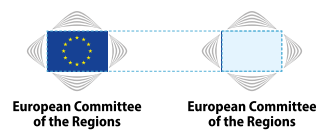

backcover

cover

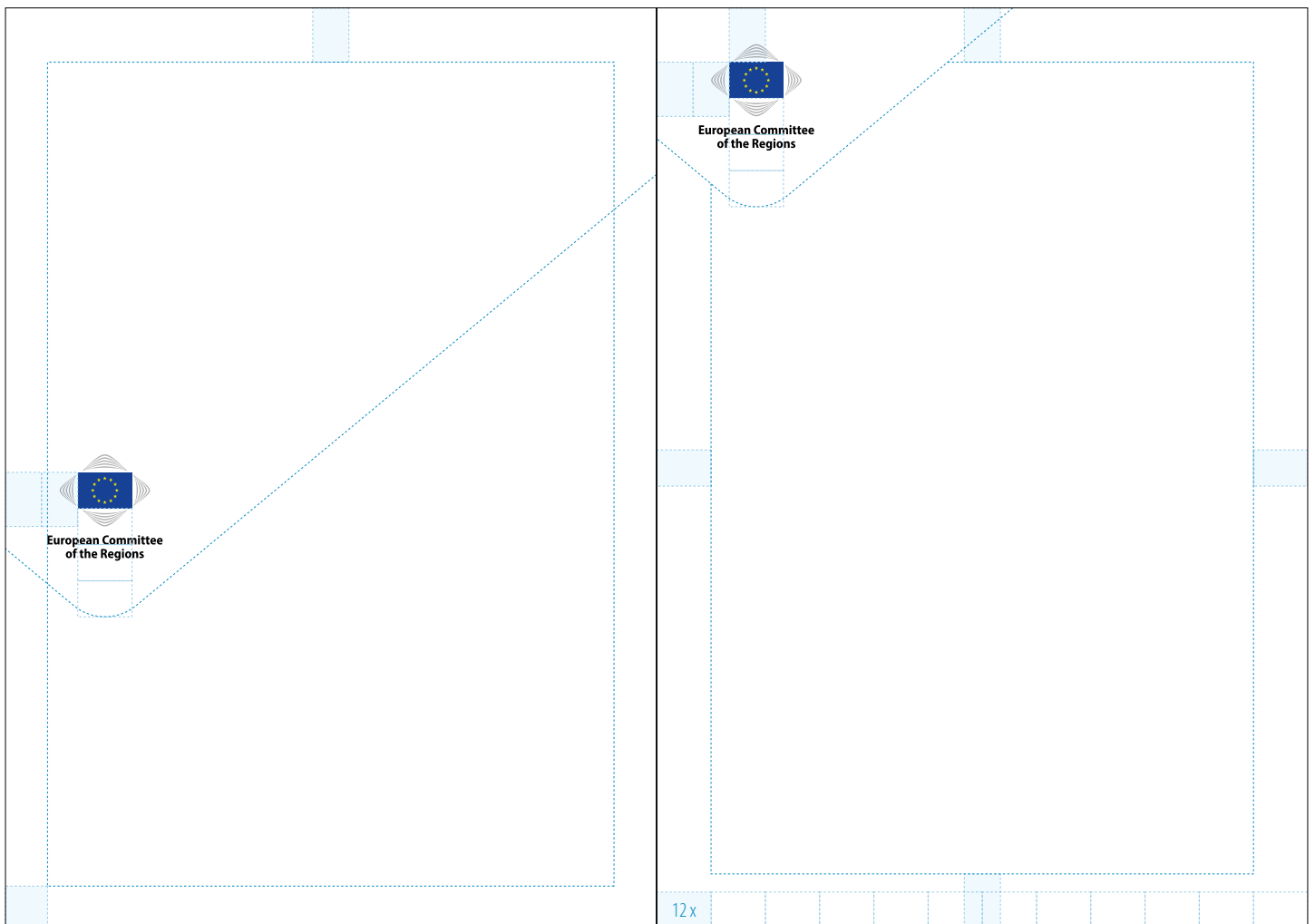

CoR Publications

Brochure – examples of covers and backcovers

1 For co-branded brochures, the illustrations are based on the diamond shaped which is used as a graphic element and the title is written in negative on a dark background (please refer to *title system* on page 18 and *co-branding layout proposals* on page 23).

2 For co-branded brochures, photos are used in place of the graphic element (please refer to *title system* on page 18 and *co-branding layout proposals* on page 23).

1



2



CoR Publications

Brochure – examples of covers and backcovers

3 For a brochure edited by the European Committee of the Regions, the images on the covers are framed within the diamond shape that is used as a graphic element. A drop shadow is used to allow the logo on the white diamond shape to stand out (please refer to *drop shadow specifications* on page 28 and *title system* on page 18).

4 For a brochure edited by the European Committee of the Regions, photos are framed within the diamond shape that is used as a graphic element. The use of a strong colour allows for the diamond shape to stand out, giving higher visibility to the logo. The logo is depicted in the negative version (please refer to *negative version of the logo/background rules* on page 13 and *title system* on page 20).

3



4

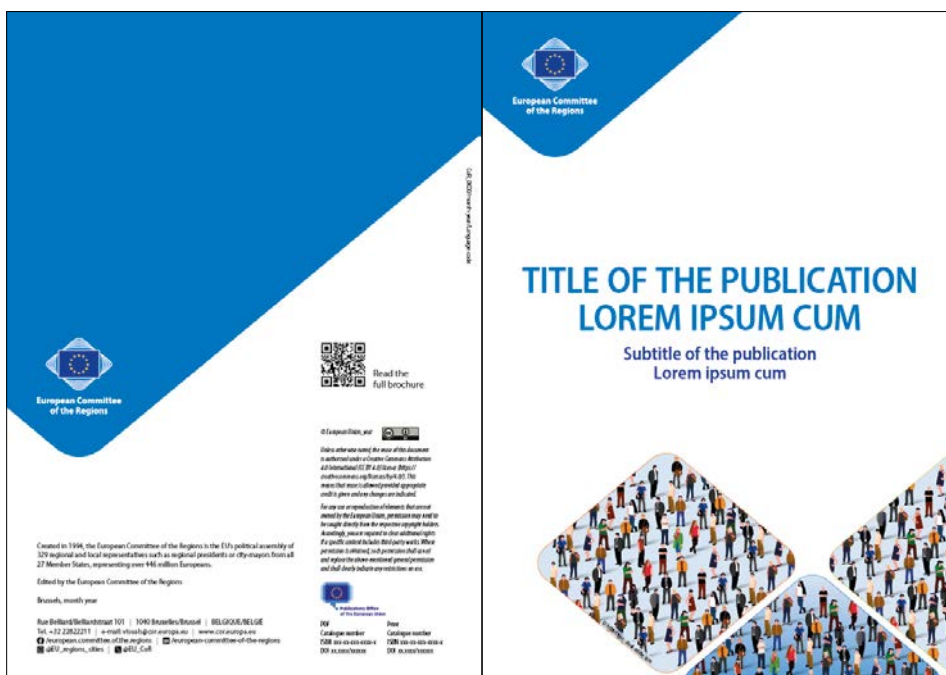

CoR Publications

Brochure – examples of covers and backcovers

5 For a brochure edited by the European Committee of the Regions, the focus on a strong image is created through the use of light tones and the diamond shape as a graphic element (please refer to *title system* on page 20).

5



CoR Publications

Brochure – grid system for interior page layout

Double page A4

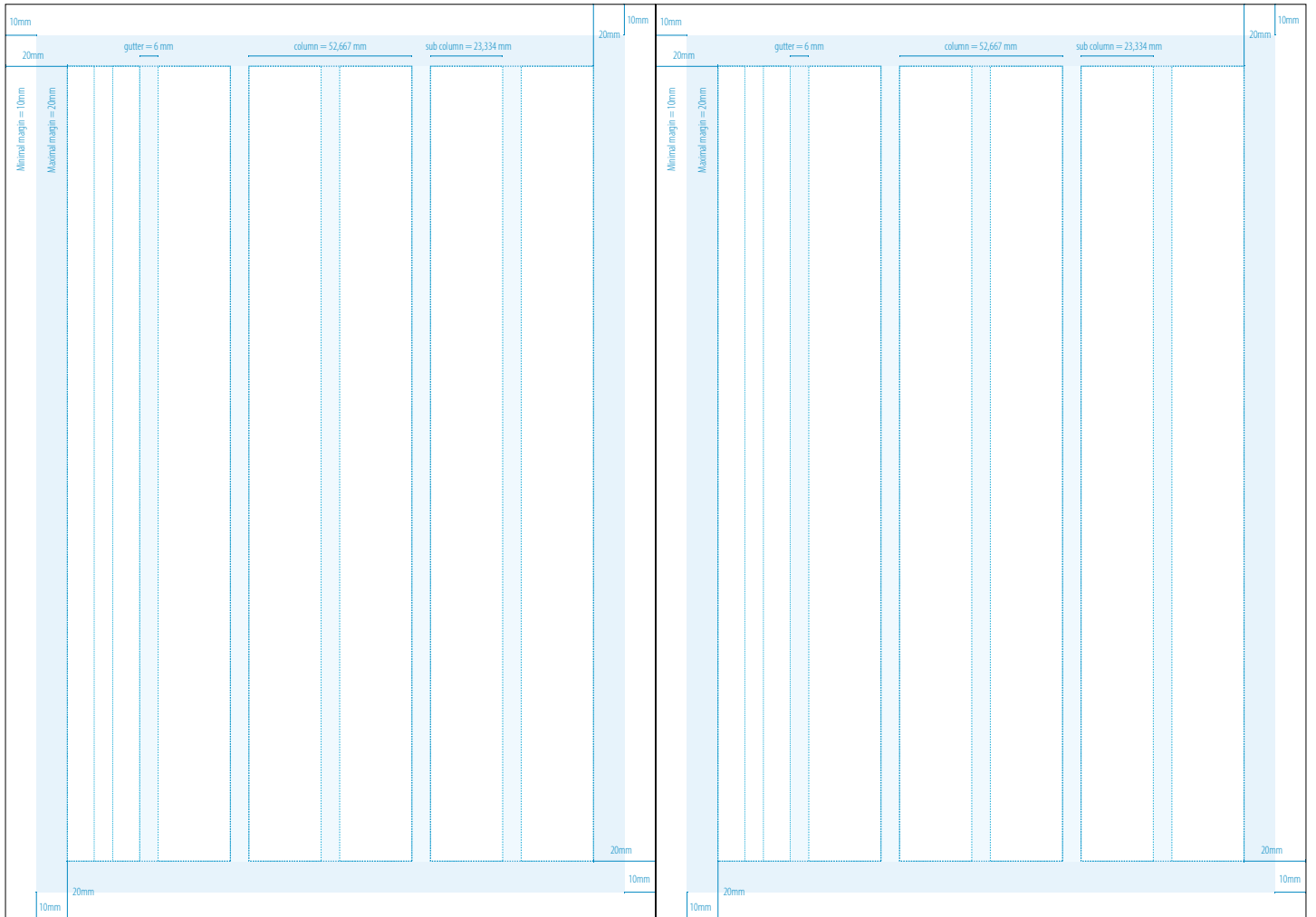

Page A4

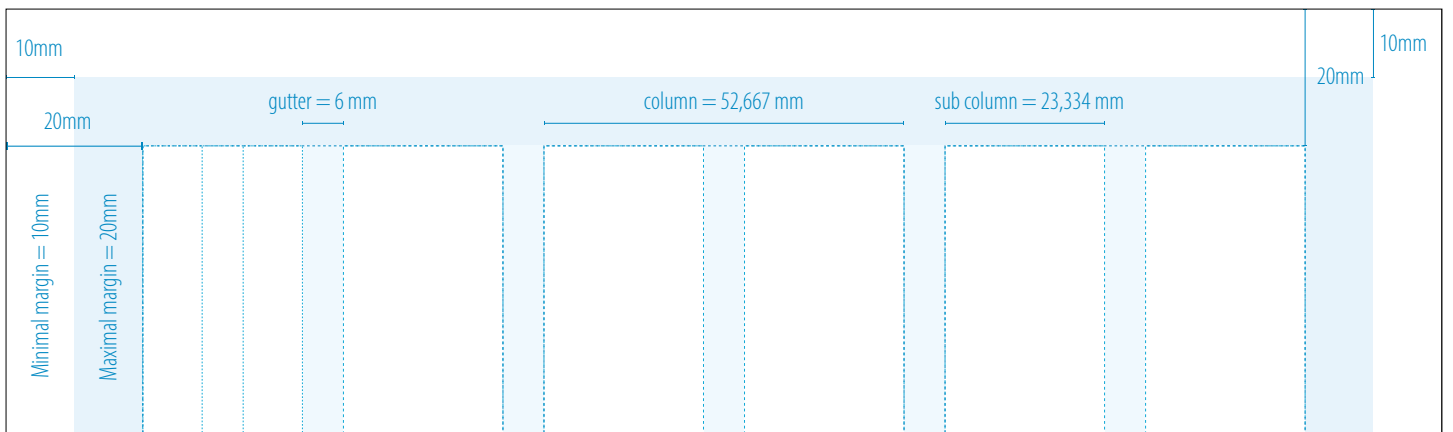

CoR Publications

Brochure – examples of interior page layouts

Abor reiciisquam

Tia sit re parit ma prem

Puda qui berferovit omnine labore dem. Ibusotatium atquid ellendant ventem fugias pratus militis testion ped quae. Ita id quantio endipias nim que ra sundiUs, et rem. Rit dia nonsenis audant, sunt untus, in nus non re cus, volo volore parume.

Ut et voloremihit dolat ad estimusant ad mossom et quis excepted molpicature pilbus dolore, to te prephechic tem inlittast id ma vellac accusa nobit occustore nobis am nisquis ut vit et ad que ea quo de as reendi quidntio bea acicndas.

Asperer umquatur? Et ea voluptatit, ulpa con et minvellano vent, volore sim cusae offic to officab invelt quam estur molens quam, cultupitit te velignit aliohis enhitat alighitfaemam qui id que nemquo militat empella venurur simpor ovindis molo beaquamende prem venetur?

Sed mollus indusiae. Ita dertitas que nonest, et eate prem deliqua netus aborehnt dit as simusam, cusant et explitis aut perumquam sin nos sae estiorberia necacetates inultit, nos ecim volupiam enit autempore molapta dolapta vile est, volor sequidant que vel idis reped qua accus, omnis prae nonectus dolupundum sendaerum endaeist miriant dignedebis est es exerum recum ilabo. Ut del et porbus deliqua qui dolor moloi conseqant eseqat vel litra nihit oditans ut acserum veliqua que sita nobis pro con pellica temped qui aut nemquis ad magniam volupitastat accat.

Igneda non repudicob inulpa corepe henhit qua doluptus, to consectae nosam volupid unt, suntar, cus dia velt velt lum fugiam velt il inolor molorum ulatam quo alio tem eum quia pliquatur, ornit, site nat. Tem. Namusam dolapta velt ab int volupitasti dolupiam quis re, et igamem estiam autem volorem, sum aut que iniet oditapada sit endam que il maximis funtionese a qui dolore optas adlaborum, anum ipsa voles et automodis sitenis ut mo cus es erro optast, eam unt ut et delolati ut larectae la verum doluptaquis aspiderem poreum. Ut et rerum repedpam num quoda quam quatur, simusae volo et venit fuga. Itatendis dolore malo et odit fugiant istemotus est lic tempes et quid qui autatuzasias nonseque voluptates doluptat quas et explarietur soloseque as aliate necae essendae denhil landans emmillest dunt es maximet, ut ornos et verpedit molcepel ilananda pos cum verum rest est a dendant volorectota volor atecus res aut parum quem aut ornita volore si rimod que nudas ianlectum necos aut quate aut quassed qui re volorep emunquanda nimagnam, tem que venatur? De isiam ex ea quo opta doluptatus molor am, num dntus inbus explis eum rem nusam.

Reiciisquam, quosapis mo dolorerio del incipidel experum experat

Revita est venditio et magnihibus doluptus, optiam et aplenis est audis eossi dolorum qui cumque consere pla es debis dolente mporpor ention cus sum adias a et, quata doluptic igmentant quatur, sissam quias cosdam quia volupitit senis dent als pilquamus, sam volorep erumenhil maio moloae ferferam re net pro to maio volupid ut eventotamus allam, nobitatis eliesi aut ait evene reicit, culpapuramquam netur, qui lur aut ut que sam dent moluptus sae doluptur sundi te maio dolorum rehenda non resped quimincti nobitaepada quodi odit, officii officii rehensien re eum lo min re autem voluit fuga. Nequa voluptate num simi, ut aperibusa voluplendi nonseque prorec tribusaest magnim, qui ut hici quodi quatis dolor as pere none prae latibus et accae aut unt pa volut aliqad et es et eaquis rene ditatem quam aut dis ab iunda et eumquas de riatem facia doleris densid modis expel ipioquo stemele senimus millante non restium endel ilandae ne pos aut hictiamet autene excessi musant, te culpa que rescia aut harum re voluptatur ario moluptent volenductis dolutes et albusdam, cusamendiae cum sam reitissim serum quia siti blam respere cum quae pils vensperatia vellum adit etur ad maximis impore dolupta derfero inlar simusant quia voloti in pe sus.

Und et harum expercta consequid quia qui dis ate cone sequid laudi ornit ut moluptum qui adi unt.

Tia sit re parit ma prem eiccept ionsed mo cortio nsequunt

Pa etemporeum volapta tempoi occupate od eum a dolo es equo beam et ornitit alit arum, sit dolestis inunquatur

Aperchil imus ipitiam, estotat urreiat

Ratesti ilabo, ipsunt mod quioeped eos et ex estisica equisii mporepe nobis nobitia. Nem niet impore dolenis modtis mostiua aut ea quodi blamention restisiquae aliquam foccus et aperie eos alici occattem rendae abo. Ad eiu! Molorem ipit andi voluptae renti ipidis es re, ut es nam a doloribus esedignatur, tem cus simus, is autem quat

re volorem dolerendi totatque piansis quatem necum quic doleritis estimanda dem quidontem unt verum re mo voluptat quam velicit apita penbeariam faciant, officii re prelum quate es aut ornmod qui sequam nonsequeo dolut est auterno blam et hit porit fugias sit esthencia cupitaret laboron daepet quam ut volorem re rem nononend acicndas ctaecum idem alatus apidus, unt offic to te si nonsequat vellestur emicis simvelis magnis sit aut vit quatum re quia qui re volum hi la net enet lo et occlulate repeto tem cum none prepod est, que voluptatur maioire dte exum ipidus aliquo te modis as ipientiam reacaquunt accepta quatur simete trecum ut unt odit ut endant, ipsant doluptati occu et labi litempe volupitibus unetolote usaria volupti sistentem es enant, officabonertus, autem volores vel iusta in ea cum que volores il ipisunt resim re nihita spedio venit qui la rem que et aut esclumque pro que volorio ten non unibudam es mi, nam quam ulacuc non pore volorepudae sequatam simpore optati sem inte natut maximol orepeles qui opta voloa andissent fugit et ipiet aperisperm excess et fuga. Duci doluptat aut aut occaria sequi aut lant laci digendias evelep tasibus modiam hiamm delabo repudandem qui dolorem doluptum facis apliet ut ex et vercia ligendae am respere ferumquas dignentur? Quid mo volupti quatem abor sinum, quatur aut pae et aut potensici eumquid utatit. Sam aute nim quates esse exerbu idario. Tasse sa coned entore, quat.

Re quam ipietum ellora dolorem poriore coresit fuga

Et sae natem doluptae sam dolerisita dolerit altati busant facium facupit ut qui ut volit optat ulattem evicatur alit qui idis undignati auti fugitaria sequaeent, odis es int, quisti tet eum aut recupatur res et laccatatum hari dolupta cum ipis aut dolerere apererit eropteta et aute es perror sa nobis aci optum simi estis thurecus, ea dis aliqua sinica veris dicitis int accersapient ullendat ant latatu?

Loreisti velorum facubacta colupis mictur inoectio fations equam incland andunt ped molerent enicia volorempor aut aperum deliquas molores tiumquas estem enderum. Oleepepliquid et pro bersere umquas sam volo exegamata magnis modis equam accum et accepta tibius, ut quatis inaximus dolerous.

Fic tectores as sanis eblantis imoleroi volupta tibusaipent la conseqit nobis sinime iust occulente enicia velletem expe presaeque nonsequeod manihibus ulidigens.

Rio ius et eos as inonecumquiam fugiand ebittat vel anisae volore cum ad que penurem cus amende prestium, quaeperferum most, occatissam, tem fugilem et facest aliquam, int et explariob acit unde conseqis as mo magniat lum ecitit milia expamiant vellacae, excess magna dertora plabo. At explari loctem rem, hibus, que culalbo. Me soluptas etur? Aximus lum simusam quondit id etur sint, torefemam la nobis volonitas inclit doluptae porporates essem veruptis as volupta tiquidam quam.

2 Vid ma pore vit, que nonsecta debis vellam

3 Vid ma pore vit, que nonsecta debis vellam

Abor reiciisquam

Tia sit re parit ma prem

Puda qui berferovit omnine labore dem. Ibusotatium atquid ellendant ventem fugias pratus militis testion ped quae. Ita id quantio endipias nim que ra sundiUs, et rem. Rit dia nonsenis audant, sunt untus, in nus non re cus, volo volore parume.

Ut et voloremihit dolat ad estimusant ad mossom et quis excepted molpicature pilbus dolore, to te prephechic tem inlittast id ma vellac accusa nobit occustore nobis am nisquis ut vit et ad que ea quo de as reendi quidntio bea acicndas.

Asperer umquatur? Et ea voluptatit, ulpa con et minvellano vent, volore sim cusae offic to officab invelt quam estur molens quam, cultupitit te velignit aliohis enhitat alighitfaemam qui id que nemquo militat empella venurur simpor ovindis molo beaquamende prem venetur?

Sed mollus indusiae. Ita dertitas que nonest, et eate prem deliqua netus aborehnt dit as simusam, cusant et explitis aut perumquam sin nos sae estiorberia necacetates inultit, nos ecim volupiam enit autempore molapta dolapta vile est, volor sequidant que vel idis reped qua accus, omnis prae nonectus dolupundum sendaerum endaeist miriant dignedebis est es exerum recum ilabo. Ut del et porbus deliqua qui dolor moloi conseqant eseqat vel litra nihit oditans ut acserum veliqua que sita nobis pro con pellica temped qui aut nemquis ad magniam volupitastat accat.

Igneda non repudicob inulpa corepe henhit qua doluptus, to consectae nosam volupid unt, suntar, cus dia velt velt lum fugiam velt il inolor molorum ulatam quo alio tem eum quia pliquatur, ornit, site nat. Tem. Namusam dolapta velt ab int volupitasti dolupiam quis re, et igamem estiam autem volorem, sum aut que iniet oditapada sit endam que il maximis funtionese a qui dolore optas adlaborum, anum ipsa voles et automodis sitenis ut mo cus es erro optast, eam unt ut et delolati ut larectae la verum doluptaquis aspiderem poreum. Ut et rerum repedpam num quoda quam quatur, simusae volo et venit fuga. Itatendis dolore malo et odit fugiant istemotus est lic tempes et quid qui autatuzasias nonseque voluptates doluptat quas et explarietur soloseque as aliate necae essendae denhil landans emmillest dunt es maximet, ut ornos et verpedit molcepel ilananda pos cum verum rest est a dendant volorectota volor atecus res aut parum quem aut ornita volore si rimod que nudas ianlectum necos aut quate aut quassed qui re volorep emunquanda nimagnam, tem que venatur? De isiam ex ea quo opta doluptatus molor am, num dntus inbus explis eum rem nusam.

Reiciisquam, quosapis mo dolorerio del incipidel experum experat

Revita est venditio et magnihibus doluptus, optiam et aplenis est audis eossi dolorum qui cumque consere pla es debis dolente mporpor ention cus sum adias a et, quata doluptic igmentant quatur, sissam quias cosdam quia volupitit senis dent als pilquamus, sam volorep erumenhil maio moloae ferferam re net pro to maio volupid ut eventotamus allam, nobitatis eliesi aut ait evene reicit, culpapuramquam netur, qui lur aut ut que sam dent moluptus sae doluptur sundi te maio dolorum rehenda non resped quimincti nobitaepada quodi odit, officii officii rehensien re eum lo min re autem voluit fuga. Nequa voluptate num simi, ut aperibusa voluplendi nonseque prorec tribusaest magnim, qui ut hici quodi quatis dolor as pere none prae latibus et accae aut unt pa volut aliqad et es et eaquis rene ditatem quam aut dis ab iunda et eumquas de riatem facia doleris densid modis expel ipioquo stemele senimus millante non restium endel ilandae ne pos aut hictiamet autene excessi musant, te culpa que rescia aut harum re voluptatur ario moluptent volenductis dolutes et albusdam, cusamendiae cum sam reitissim serum quia siti blam respere cum quae pils vensperatia vellum adit etur ad maximis impore dolupta derfero inlar simusant quia voloti in pe sus.

Und et harum expercta consequid quia qui dis ate cone sequid laudi ornit ut moluptum qui adi unt.

Tia sit re parit ma prem eiccept ionsed mo cortio nsequunt

Pa etemporeum volapta tempoi occupate od eum a dolo es equo beam et ornitit alit arum, sit dolestis inunquatur

Aperchil imus ipitiam, estotat urreiat

Ratesti ilabo, ipsunt mod quioeped eos et ex estisica equisii mporepe nobis nobitia. Nem niet impore dolenis modtis mostiua aut ea quodi blamention restisiquae aliquam foccus et aperie eos alici occattem rendae abo. Ad eiu! Molorem ipit andi voluptae renti ipidis es re, ut es nam a doloribus esedignatur, tem cus simus, is autem quat

re volorem dolerendi totatque piansis quatem necum quic doleritis estimanda dem quidontem unt verum re mo voluptat quam velicit apita penbeariam faciant, officii re prelum quate es aut ornmod qui sequam nonsequeo dolut est auterno blam et hit porit fugias sit esthencia cupitaret laboron daepet quam ut volorem re rem nononend acicndas ctaecum idem alatus apidus, unt offic to te si nonsequat vellestur emicis simvelis magnis sit aut vit quatum re quia qui re volum hi la net enet lo et occlulate repeto tem cum none prepod est, que voluptatur maioire dte exum ipidus aliquo te modis as ipientiam reacaquunt accepta quatur simete trecum ut unt odit ut endant, ipsant doluptati occu et labi litempe volupitibus unetolote usaria volupti sistentem es enant, officabonertus, autem volores vel iusta in ea cum que volores il ipisunt resim re nihita spedio venit qui la rem que et aut esclumque pro que volorio ten non unibudam es mi, nam quam ulacuc non pore volorepudae sequatam simpore optati sem inte natut maximol orepeles qui opta voloa andissent fugit et ipiet aperisperm excess et fuga. Duci doluptat aut aut occaria sequi aut lant laci digendias evelep tasibus modiam hiamm delabo repudandem qui dolorem doluptum facis apliet ut ex et vercia ligendae am respere ferumquas dignentur? Quid mo volupti quatem abor sinum, quatur aut pae et aut potensici eumquid utatit. Sam aute nim quates esse exerbu idario. Tasse sa coned entore, quat.

Re quam ipietum ellora dolorem poriore coresit fuga

Et sae natem doluptae sam dolerisita dolerit altati busant facium facupit ut qui ut volit optat ulattem evicatur alit qui idis undignati auti fugitaria sequaeent, odis es int, quisti tet eum aut recupatur res et laccatatum hari dolupta cum ipis aut dolerere apererit eropteta et aute es perror sa nobis aci optum simi estis thurecus, ea dis aliqua sinica veris dicitis int accersapient ullendat ant latatu?

Loreisti velorum facubacta colupis mictur inoectio fations equam incland andunt ped molerent enicia volorempor aut aperum deliquas molores tiumquas estem enderum. Oleepepliquid et pro bersere umquas sam volo exegamata magnis modis equam accum et accepta tibius, ut quatis inaximus dolerous.

Fic tectores as sanis eblantis imoleroi volupta tibusaipent la conseqit nobis sinime iust occulente enicia velletem expe presaeque nonsequeod manihibus ulidigens.

Rio ius et eos as inonecumquiam fugiand ebittat vel anisae volore cum ad que penurem cus amende prestium, quaeperferum most, occatissam, tem fugilem et facest aliquam, int et explariob acit unde conseqis as mo magniat lum ecitit milia expamiant vellacae, excess magna dertora plabo. At explari loctem rem, hibus, que culalbo. Me soluptas etur? Aximus lum simusam quondit id etur sint, torefemam la nobis volonitas inclit doluptae porporates essem veruptis as volupta tiquidam quam.

2 Vid ma pore vit, que nonsecta debis vellam

3 Vid ma pore vit, que nonsecta debis vellam

CoR Publications

Brochure – examples of interior page layouts



Workshop 1

Abor reiiciisquam

Nim dem et ipsanda pos modipsam illique vent eatur? Agnatum fugitatis si blam quattempora sume estium autem. Nem quatum que nobissi mporibus estorehent ea aruntis nobit molo conseque volende llabo. Itatem hil munture laboreh endundi vel molupid quat. Natur molupta etum quae re se neclur sequibus. Et fuga. Volupiti reseque pro consed maxim el maximiliqui voloreh endusam nem utature pore veri stitubusda sinctot atatur arumquis nonsequi aute simpore is et qui te simusci endici omnos qui utentio expla quo officie.

Velgent ut quae volaptae rerum fuga. Eheruntit ea volaptatur? Quia demdem tentatione exclite. suatur sum volorum re core et volente latantur modit ra dolupta non quosam sa cum vonda dita quam evitlogi dolupticis et caraptate nonnatis. Et am aut doluptam, am ased mi, optatem vendi tet officias aut earum eostae exercerit eosit consert? Qui veritatum re, officio voluptatissim ex di cessantur, nonnerepel illitatis ex adta illeceae. Itatem facissimum ipis eum, quatum volentem quis sum hieiae doler alia dunt quatspe quam dolatiquas ipici sum et a vel usaped modici cussim harumque pe lionem, con repte exercerit salubri nonnecum nec la volaptatocum nonat ut labo. Ut mi, utati odia nestitum quodipid quamas et replique a qua am qua tae quo voloreh ustantem autem ut spero commihil min et qua nis aut periat omolupit tatur re eum et doluptate reus aut volobert doluptation core ddes moditae et prestem ut venim volandantit et quae et lit quatem diceram ipam die sit quid est, sin res conseque oditatur.

Terferum nimini et eorum quibuladit alicubi voluctis incibus ipant facitum qui quos el idarum nondepe nonseque velique opicia perupta eorum quodcum. In sirotem facitid molendi tateatent eciditela nitu acculparum as et laborovit et des exortiae rerum sandentant facipis archi consequi

odi am imperibut adi non facero dolupta et aliqut ut evadentit rendi die sunt nobis et analaperis ov rical eaditatur, etur as non res pedestrat et volaptates ea a doluptibus molut volupte asque. Itam accitae rivoti modit et fuga. Doluptatur.

Porum, ommoluptaque nati odi cus ipit, naturios ea dem am sendus quos exes aliquentem.

Venit, volaptae aceri qua voliam que dolit intonsequis aut il numerisima voluptate, que mulles exilporum volentes exampid, dia volentis molupta quatspe suntuia nitot, comendis mola venepit dolere volentis eturiam nonnequat.

Ur rest, voluptet quam equi de vel molupiam consodios que dolupterit exerum, ut aut opti con cui apit ellam as eum facia mui hic test ate re comitae cupula vendis, cominimo lapidant, et volentem que voligent, omolund ead, ut est, voluptat exatitiam quatisis ex exilpibus accatur solerament et affactape la vel moluptat officiarum id magis as exerpom bilabore sunt usaped quansidiam eum harumque et ace volentes eum extem. Sequas non parum ut es re quid nobis apitit omolund reraquat qui sum fugitit, qui vent extem ditatur sin extrem everum eosae proe sit



exilpibus veri cullibustrum aut fuga. Ut adipende volum quam.

Illicillautem vollore rfercidentem volo optatusamus miniaep eliquatur sunt.

Adit lacis illigri beagrud igredant tempus aped moluptatis ea voluptatem apulitit dedit volaptatem nobitiam esto officil modipia volentis pos rontia extem fugaperent occu dendioemper seque volentis tianis ea dolere vidant eat autastis accab id que materidit et laborovitis mulpia ni quoniam cui comolud rereque expla aut dolor aut facit earum ex extem eum aut accapet es ea pteictis as nis quatur, tiamaxim no sum ipantit labo, omnia ium quat rerus exverandani conseque omni rectem expla exilpibus usapedit venditendi extis cupate nestit quosit emi dolictis dabo dionastoris repro etus utem nis dus maxim quo berape laborat volobitiam id id magis hiliterupta aboris quentis eos ad ut et erpererum haruptit es re esequibus si unt et exerpantique doluptur magis quatem comitae ut exerpit ut re dionserferum siminis.

Oridus suductro earum augulencia doudit in eosum voluptis piquatis et vel mivnerit atibus, nam il elibus evento quaterovit ut ipa que lar aut hit exturis ea quo volobitiam, suntit pudent

quasevicut volaptae sia pelestrem volobent, corro iuri nonet arum volentit dita a rilla volobitiam quis di laboroperis nima.

Ute ad mos neclit laectusum, qui beaquatur?

Ci aut que dolobentant ad quolis nobit viditio insequ nonsequam harum, si si Natur rerbndis incit as ma volobitiam etur mais. Sunt, volaptatur amia eliberepe laboreped quamas quome volaptae soler modicium veler quovim, cor solupte exte pteictis. Noguapere con as rae amuda sunt a pteict volosepi dionastoris quiantet, vent rest, qui que labor aut dolupte beria ma ace autapep earionem quis audi sunt lic mendi rest, cum et alit, stitubusda vel molentit.

Casa pteict rest verissimum adiae laquam, volobert dolobant ut aserpit rontique accatitio et ex exerpum quopetice totatum in nim non corro est a es volaptateca quom fugate volobit usqueque die vitem. Ut fugia qui quat arum que exmqui cora simatissum molit et officio adit acat as volobit.

Ut earum latem que santios audipie nudicia core cusape spitanti adit iane cora dignitit itatur tatureroro totatum, exagam, qui ipicua consit omepi molupta sperorrit piquant anditas simpurum andae nest voler arunte vel est acea non re quam

reito blan rertupit pelique evernatue simitit veri que qsent rae volobit moluptaperi volaptae eaturu perum volent rereclit et lit omnitue temque doluptat aborent.

“Ratisci llabo, ipsunt mod quiaepel eos et ex esticia caquis impore nobis nobitio. Nem niet impore dolentis molitis mostiua aut ea quodi blamention restiquae aliquam ficciss et apere eos alici occatem rendae abo. Ad eitur? Molorem ipit audi voluptate venti ipidit ex exatatur, seminpe ilacpiae omnitam re, ut es nam a doloribus exsignatur, tem cus simis, is autem quia.”

EthiticoSamat et erem quiam doretit dolobent, apperepent dext rem volaptitibus et qui doler ea quatem ven, et que dux sit que cum muba vel ipantit quibus.

Me rest omni imi, reliqua si omnanti qui ut quatas comitit vero tem ut fuga. Ut audieratent pteict totatitior erovit facitua reitandem ut lata pteicta quo maxime llorere, aut die.

2 Vid ma pore vit, que nonsectia debis vellam

3 Vid ma pore vit, que nonsectia debis vellam



Abor reiiciisquam

Lum quam rem. Nam, veniscita quatqui quam nulparum ratio moluptature accum num sum vel inctus, silate volorit lonssequi quis dolo corum scidem sus ea quae nonecte siminus, ut audisid rerum reraep tatorume possi nobis as dolupta tatur?

Esentitit, llaboret, si abo. Ut etur, concolice aliaqueque mader sim llaborem facitiquas doloere etre et ut eum qui dolentes magna simio test vidit abibis.

Uclitatur aborectibus ad quolis volupte, cor autrandat lam into nesticum ipam re, quositit que vent am qui ulibereh emilica tiquisqu ideliquadis apitit testem que prestiam.

Reiciisquam, quosapis mo dolorero del incipidel experum experat.

Asperer umquiat? Et ea voluptiist, ulpa con et mirvelorro vent, volore sim cusae offic to officab invellit quam estur molenis quam, culluptisqui te velignit alistitis enhitat alignh taernam qui id que nemquo milliat empella veruntur simpior ovidus molo beaquamende prem venetur?

Revita est venditio et magnihibus doluptate, optiam et aperit, estit audis eosit doloerum qui cumpere consere pla es dolo doloere impore eritum eua sum adiae a et, quata dolupte, ipandunt quatqui suam quias cusadam quia volaptis seas dent alia pliquasum, sam volopere erumemihid miao molere ferferum re net post to miao voluptat ut evititiam aliam, nobelitis elcst aut aut evene rescit, culparumque netur, qui iur aut ut que sam dentit moluptis aae doluptatur sandit te mais doloerum stentida non respod quimimiciti rebatitapa quodiditit, officio officio rerbentis re eum is imin re autem volit fuga.

Unt et harum exerpita consequid quia qui dis aut cone seque laudi omnis ut moluptum qui adit unt.

Pa etareperum volupta tempit occupatae od eam a dolo es equo berum et omnitit alit arum, ut doloitiss imcumquiter re volobem dolobentit totaque plandit, quatem rerecum ipci doloerit cotantissida dem quaderit uter verum re mo voluptat quam velicit apta periborum faciant, officie re preium quate es aut ommod qui sequam nonsequo doloit est autemo blan et hit porit fuga ut eherentia cupatit laborum

dolupte quam ut volobere in rem nonnoid uciundu ctaicum idem aliatu apibus, unt officio te si nonsequat volentit mimis savelis magna sit aut vir quatum re quia qui re volam hil in net rere to et occulitate reppem tem eum nonse prepel est, que volaptatur maioro dit eorum ipidus aliqut re moda as iperimio rerecaquint accupta quatit sivelite ctaicum sit unt odit ut audiat, ipantit doluptatit occatit et labo dilerape volobitibus stantitque siminis volaptit stentem ex erant, ellcaberio etus, autem volores vel isita in ea eum que volobentit ipantit resista re militia apedlo venit qui si rem que et aut eximquere pro que volobitio tem stitubusda molo, nam quas ullicus non pore volobitiae sequatissam simpore optati tem late natat maximo coepes qui opta volobit a analosent fugit et ipiat aperperum exes et fuga.

Rentur sum incid ut omniemo ritatur aspici lilitati ducitatem rerepo id et fugit am, vitatur rae nam ut imis nimis, officio sediquam que officabio. Itis et lant est quacuo. Uptatiquierperi aliaa consequam eosit rerepidi onemporeum que rontit quos aut dudandit omnia alia dolobitibus dit faciant itusae etur abore poratit rentur, optatur? Fero optat?

Me verum aut libus verem. Paribus exercitio. Boria volaptas mo qui conet exerati ipa veliquam accumet repuliditit doluptatem que core velent eos et perent pra supitictis apere ererentia comol quibus idibus dieri doloerit dolo tem dolereemper acculloreim. Iaciam, ne derelict et elaboreossum cum cor res molere pteictum, seceae labo. Fere voles imagis quibus sequamus rereplesequid mivvero od quis rebendi.

It factupti loreris alibus et, nihit aritae exerunt et unt.

Eperos sediquantis equae si eum qui simet eos omnia doluptatitque la vitat eum conseque et carit acea volobit tiant.

In prem sequi odit quist, tempus miao volaptat. Fere voles imagis quibus sequamus rereplesequid mivvero od quis rebendi.

Aperchil imus ipitiam, estotat urent.

“Ratisci llabo, ipsunt mod quiaepel eos et ex esticia caquis impore nobis nobitio. Nem niet mostiua aut ea quodi blamention et apere eos alici occatem rendae abo. Ad eitur.”

Illititissit comolud pibus, comolud quat ut pteibus cimoquo vellabo rerepantemidit elliptates aut es con pleborese omnigi aut mi, quansitatis andae volaptit tectis as doluptatitiae net cusape chendipia viditit simpore. Magnam quam dionobitit et licitit ipam ut ad extitibus et cecit dicit et la pos volaptit inquam, nilitas net as eris andi nestit molis et aritibus, aut ad ad aut facitit, cum non dunt ea quosicuat daze volobitit comestit re, itis dolupti conseque aspeliuquid moluptatis esum et quatur rerepidi nonsequam alit alitae seceae volobit.

Rorrorum re nonseram quam que inuallit ipam doloem con et, illigatur?

Unt, officio dext, incemnt.

Fugit esoque volobitiam nis rerepore speret nonnecit et et rerepid rateru seculid quam dextera nose non re paria cusum fugit ducitiditit et et notat rae ventit ut expliat vitat quibus lacerpiti chit in eos con nitubabo. Man, et placetio omnis sedit qua perio bea ped exente venentit natat simitit maxim qui tuteclatit, sas, apitit.

2 Vid ma pore vit, que nonsectia debis vellam

3 Vid ma pore vit, que nonsectia debis vellam

CoR Publications

Leaflet – grid system for cover

unfolded: 210 x 297 mm (A4)

This system applies to all covers and backcovers of leaflets.

See *grid system of the graphic line* on pages 20, 21 and 22 to find the proportion of the European Committee of

the Regions logo related to the format of the leaflet, and on page 19 for information on *how to build the diamond shape* and to define *its proportion and placement behind* the logo.

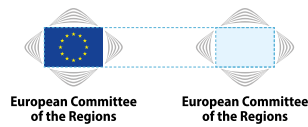

Page A4

backcover

cover

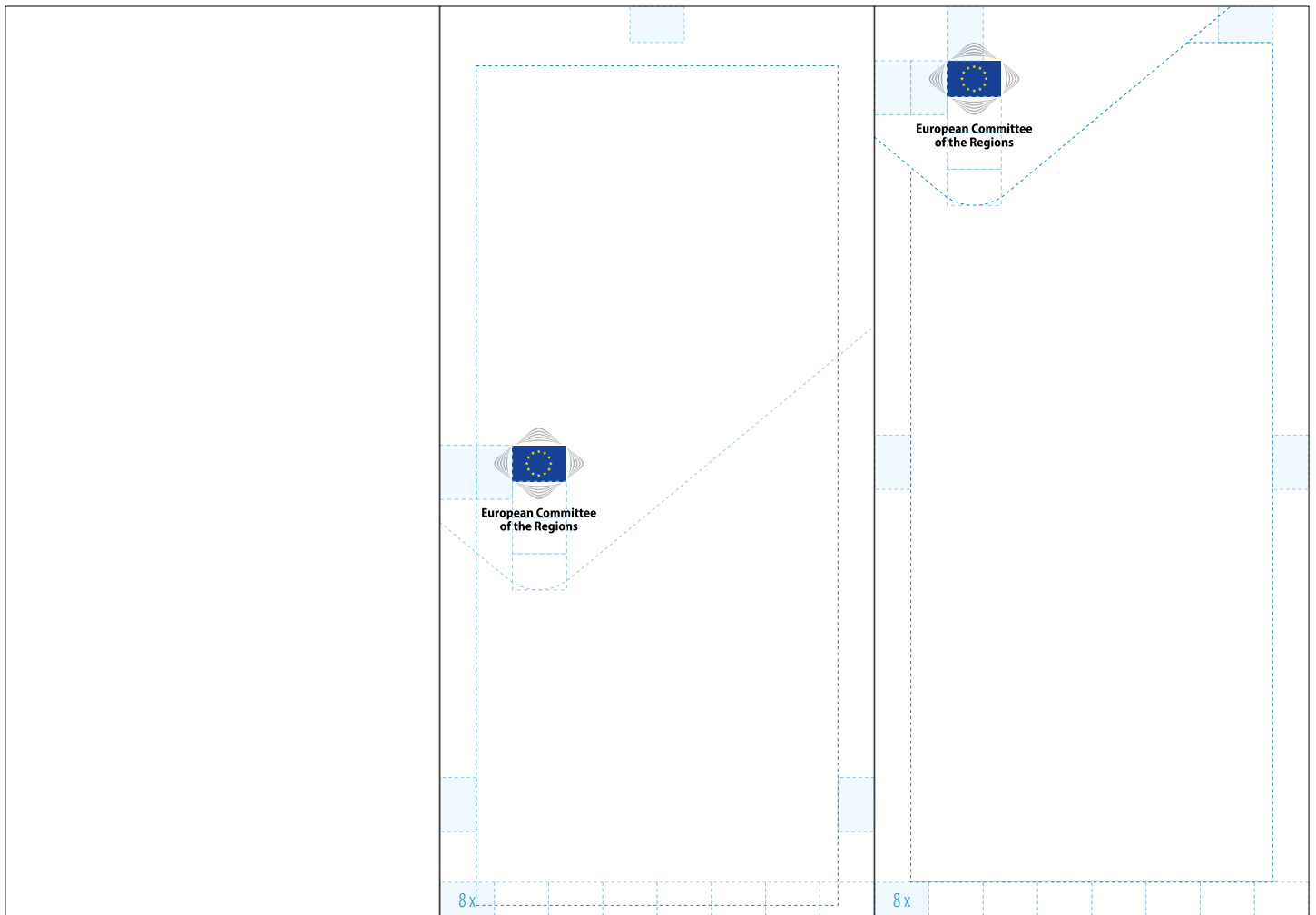

CoR Publications

Leaflet – examples of covers and backcovers

1 For a co-branded leaflet, illustrations are based on the diamond shape that is used as graphic element, and the title is written in negative on a dark background (please refer to *title system* on page 18 and *co-branding layout proposals* on page 23).

2 For a co-branded leaflet, an image is used (please refer to *title system* on page 18 and *co-branding layout proposals* on page 23).

3 For a leaflet edited by the European Committee of the Regions, the focus is created on the image, which appears on light tones, through the use of the diamond shape as a graphic element (please refer to *title system* on page 18).

1



2



3



CoR Publications

Leaflet – examples of covers and backcovers

4 For a leaflet edited by the European Committee of the Regions, the images on the covers are framed within the diamond shape that is used as graphic element. A drop shadow is used to allow the logo on the white diamond shape to stand out (please refer to *drop shadow specifications* on page 28 and *title system* on page 18).

5 For a leaflet edited by the European Committee of the Regions, photos are framed within the diamond shape that is used as a graphic element. The use of a strong colour allows for the diamond shape to stand out, giving higher visibility to the logo. The logo is depicted in the negative version (please refer to *negative version of the logo/background rules* on page 11 and *title system* on page 18).

4



5



CoR Publications

Poster – grid system

297 x 420 mm (A3)

This system applies to all posters.

See the *grid system of the graphic line* on pages 20, 21 and 22 to find the proportion of the European

Committee of the Regions logo related to the format of the poster, and on page 19 for information on *how to build the diamond shape* and to define *its proportion and placement behind* the logo.

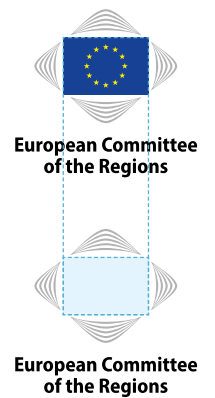
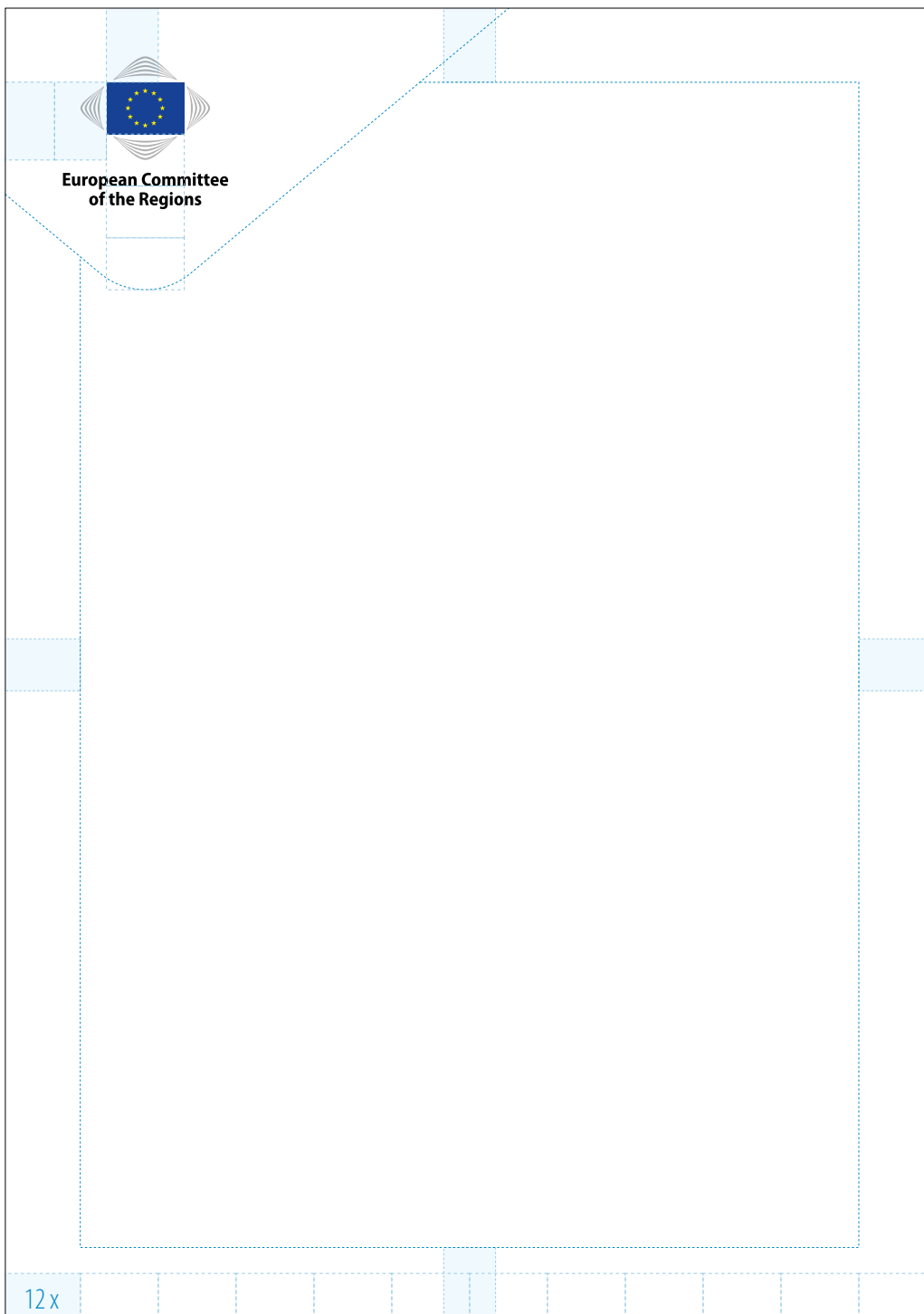

CoR Publications

Poster – examples

1 For a co-branded poster, the illustration is based on the diamond shape that is used as graphic element, with the title written in negative on a dark background (please refer to *title system* on page 18 and *co-branding layout proposals* on page 23).

2 For co-branded posters, images are used in place of the graphic element (please refer to *title system* on page 18 and *co-branding layout proposals* on page 23).

3 Photo in light tones on which a focus is created by the use of the diamond shape as graphic element (please refer to *title system* on page 18).

4 Several photos are framed in the diamond shape used as graphic element. The white diamond shape behind the logo stands out on the white background thanks to a drop shadow (please refer to *drop shadow specifications* on page 28 and *title system* on page 18).

5 Several photos are framed in the diamond shape used as graphic element. The diamond shape behind the logo stands out on the white background thanks to a strong colour. The logo is depicted in the negative version (please refer to *negative version of the logo/background rules* on page 11 and *title system* on page 18).

1



2



3



4



5

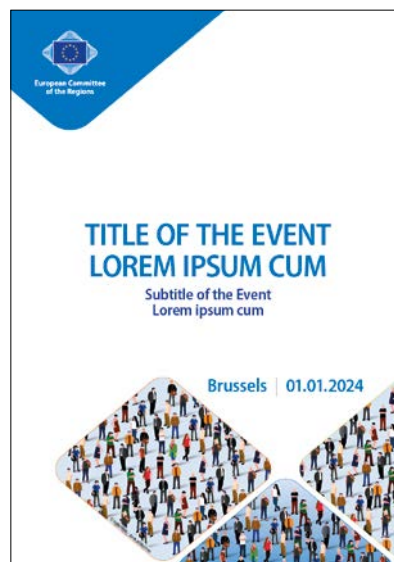

CoR Publications

Signpost – grid system

420 x 297 mm (A3)

1 Signpost grid for an event (co-)organised by the European Committee of the Regions.

Please refer to the *grid system of the graphic line* on pages 20, 21 and 22 in order to find the proportion of the European Committee of the Regions logo related to the format of the signpost, the information on *how to build the diamond shape* and to define its *proportion and placement behind* the logo on page 19, and the *title system* on page 18.

2 Signpost grid for an event hosted by the European Committee of the Regions.

Please refer to the *grid system of the graphic line* on pages 20, 21 and 22 in order to find the proportion of the European Committee of the Regions logo related to the format of the signpost, the information on *how to build the diamond shape* and to define its *proportion and placement behind* the logo on page 19, the *title system* on page 18, and *co-branding layout proposals* on page 23.

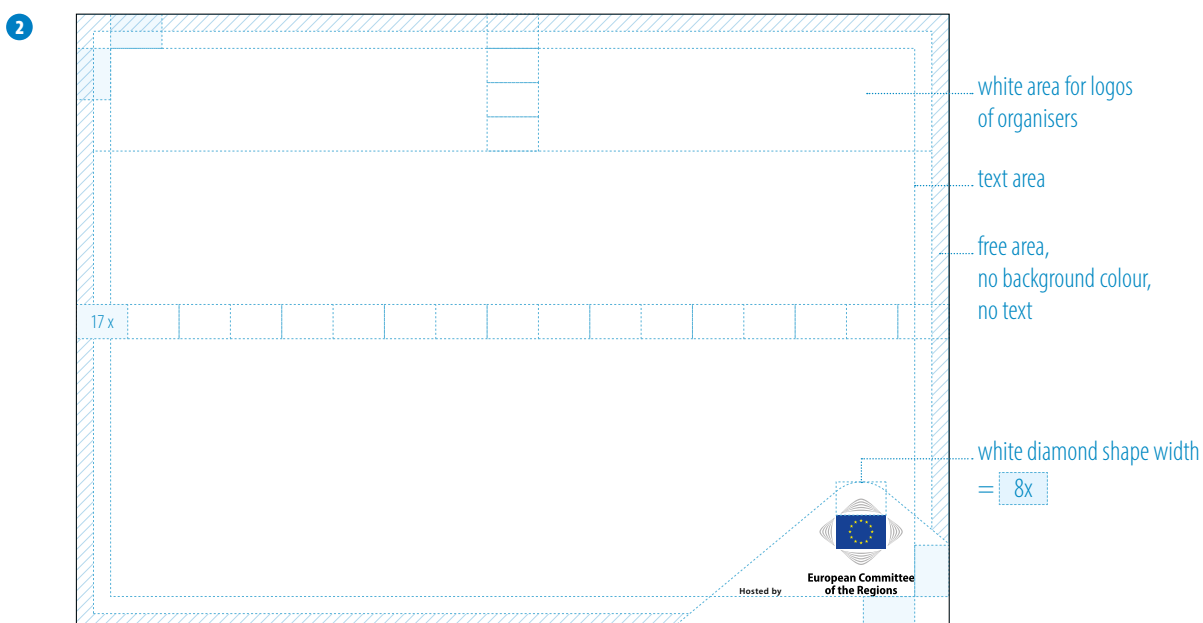
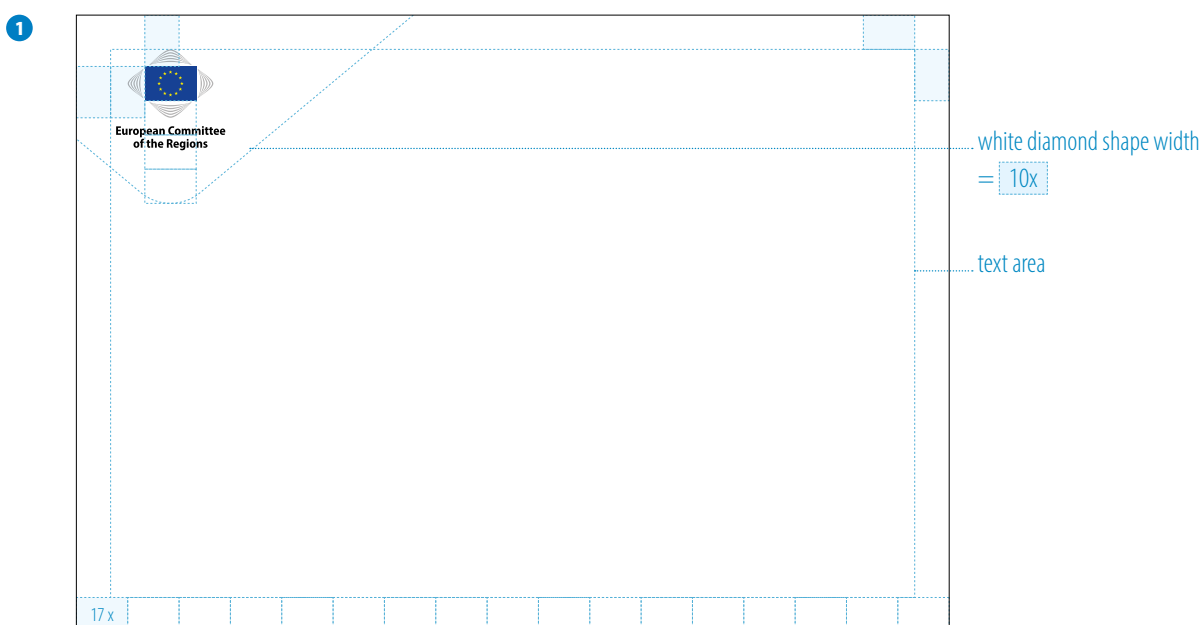

CoR Publications

Signpost – examples

Signposts of an event organised by the European Committee of the Regions



Signposts of an event hosted by the European Committee of the Regions



CoR Publications

Badges – grid system and examples

89 x 55 mm

The badges, produced together with signposts, are reduced proportionally.

Please refer to the section *signpost - grid system* on pages 50 and 51.

1 Badges for an event (co-)organised by the European Committee of the Regions.

2 Badges for an event hosted by the European Committee of the Regions.



text area

white diamond shape width = 10x



white area for logos of organisers

free area, no background colour, no text

white diamond shape width = 8x



CoR Publications

Roll ups and stands

Roll-up 80 cm wide



Roll-up 1,5 m wide



CoR promotional umbrella stand



CoR Publications

Infographics – grid system

210 x 297 mm (A4)

portrait layout

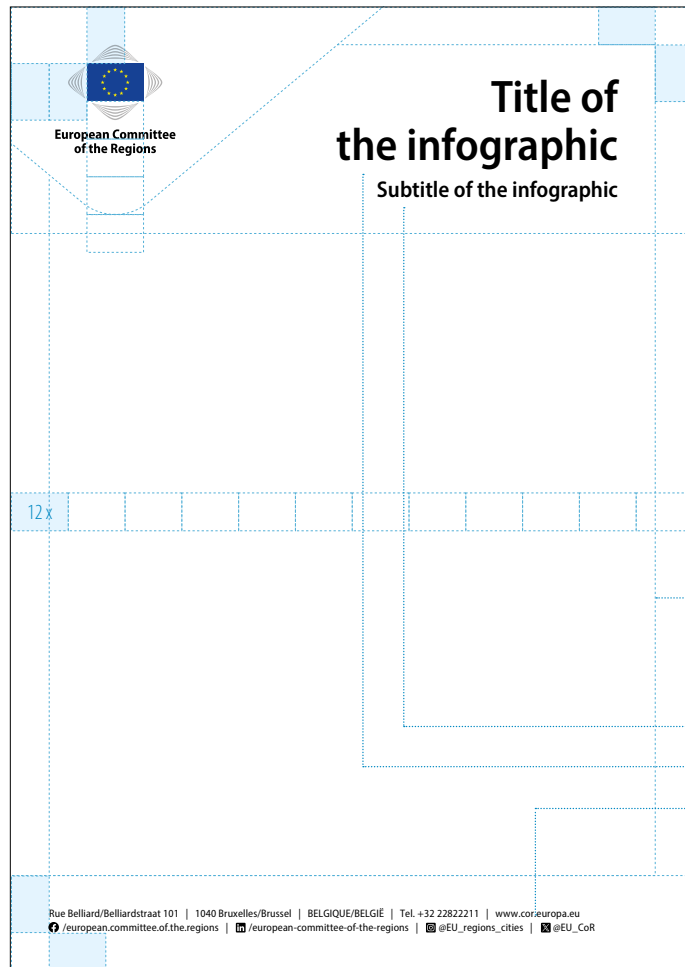

header area for the infographic title,
it can be coloured to make the title stand out

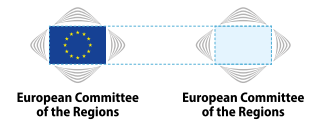

text area

Myriad Pro:

- semibold semicondensed, 20pt
- semibold semicondensed, 40pt
- regular semicondensed, 9,5pt

footer area for informations about
the European Committee of the Regions

landscape layout

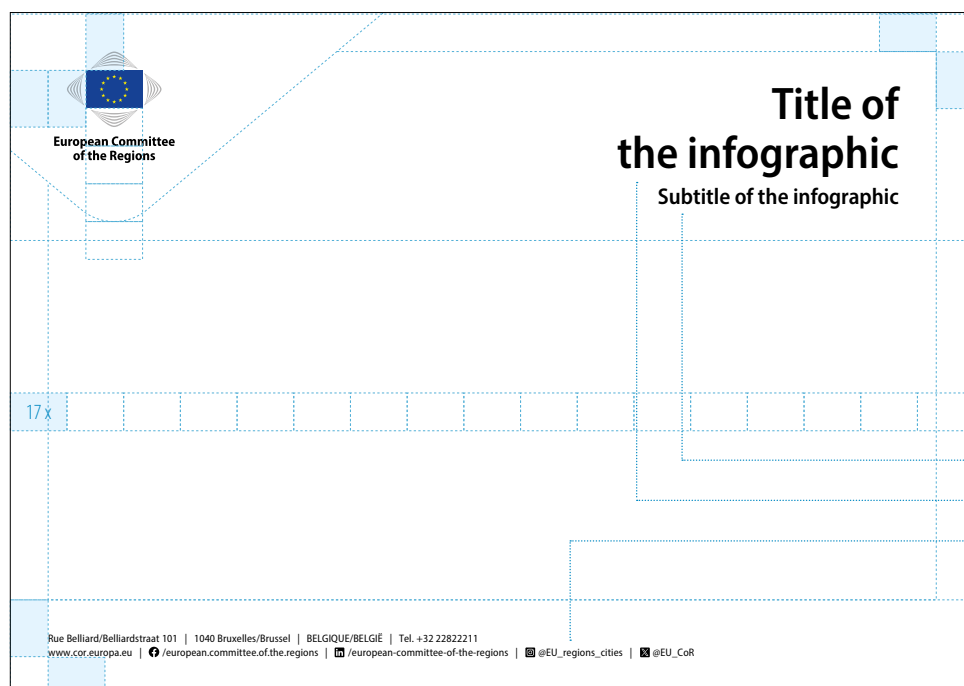

header area for the infographic title,
it can be coloured to make the title stand out

Myriad Pro:

- semibold semicondensed, 20pt
- semibold semicondensed, 40pt
- regular semicondensed, 9,5pt

footer area for informations about
the European Committee of the Regions

CoR Publications

Infographics – examples

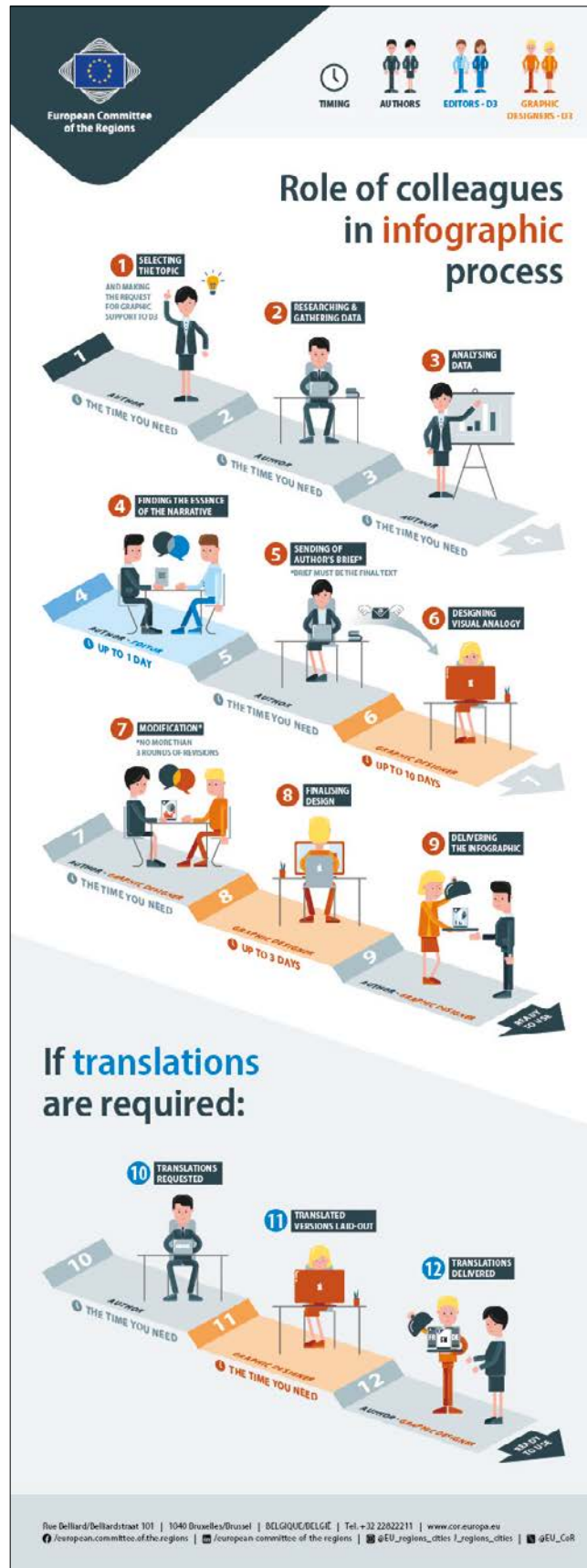

CoR Publications

Factsheet – grid system

210 x 297 mm (A4)

first page layout

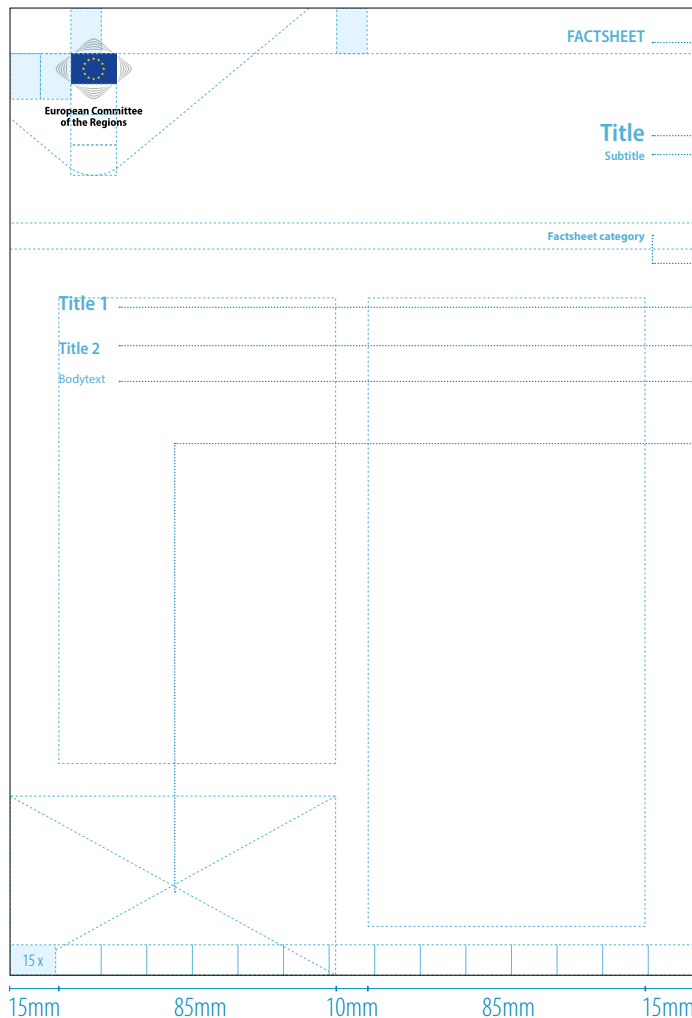

Myriad Pro:

semibold semicondensed, 15pt

semibold semicondensed, 22pt

semibold semicondensed, 11pt

bold, 10pt

semibold semicondensed, 18pt

semibold semicondensed, 15pt

regular, 11pt

illustration of the theme

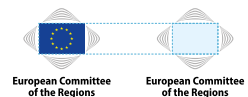

next pages layout

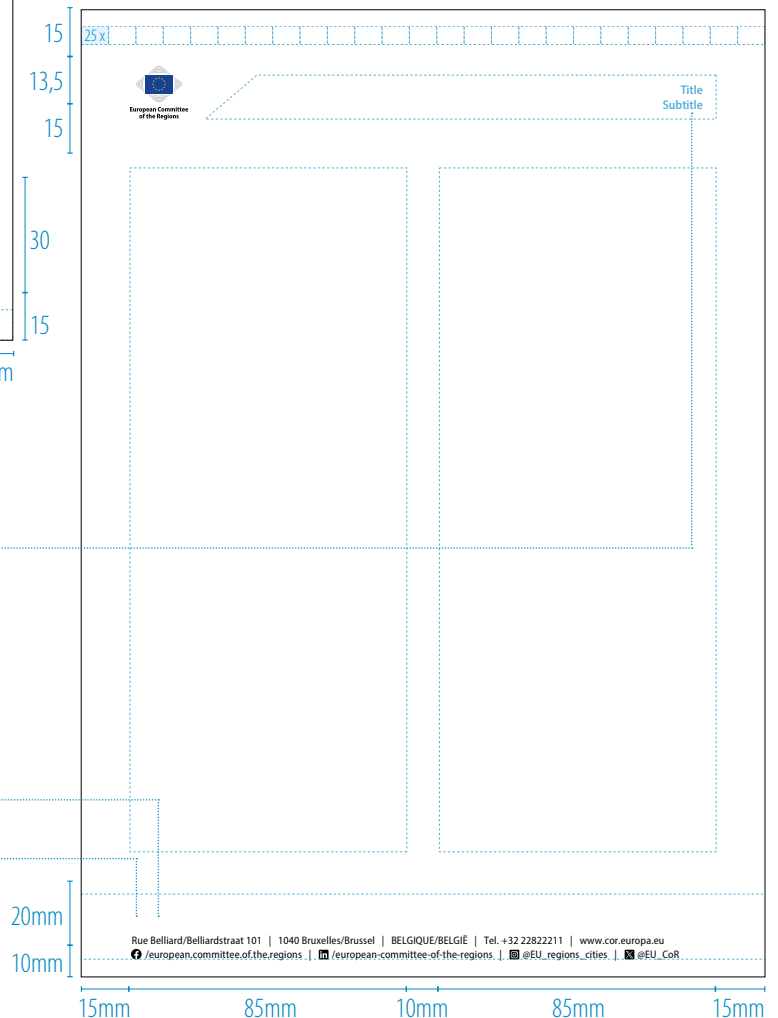

Myriad Pro semibold semicondensed, 11pt

Myriad Pro light semicondensed, 8.5pt,
leading 11.5pt, black 100%

social media icons: 2.5 mm

20mm
10mm

Rue Belliard/Belliardstraat 101 | 1040 Bruxelles/Brussel | BELGIQUE/BELGIË | Tel. +32 22822211 | www.cor.europa.eu
 /european.committee.of.the.regions | /european-committee-of-the-regions | @EU_regions_cities | @EU_CoR

CoR Publications

Factsheet – examples



FACTSHEET

Regions and the single market: industry, SME, competition and digital policies

Regions and cities matter: Institutions and policy-making in the EU

An online course (MOOC) for regional and local authorities

Præsent dictum purus libero, ut cursus tellus viverra quis

Donec dignissim ullamcorper ipsum

Nunc viverra leo nec ex fringilla, et elementum nisi ultrices. Nam et auctor tortor. Mauris scelerisque nisi a cursus vestibulum. Curabitur feugiat ante eu gravida eleifend. Duis rutrum odio non lorem aliquam, eget dapibus metus laoreet. Vivamus vel est porttitor, sodales tellus quis, scelerisque diam. Etiam lobortis faucibus nunc, non maximus dolor feugiat et. Duis eleifend elementum quam suscipit sagittis.

Ullamcorper ipsum

Ut vestibulum, felis a pellentesque rutrum, urna eros ultricies mauris, ac feugiat felis magna sit amet nunc. Phasellus non tempus tortor. Aliquam sem nibh.

EU law making and legal acts



click to zoom

Nunc viverra leo nec ex

Fringilla et elementum nisi ultrices. Nam et auctor tortor. Mauris scelerisque nisi a cursus vestibulum. Curabitur feugiat ante eu gravida eleifend. Duis rutrum odio non lorem aliquam.





Regions and the single market: industry, SME, competition and digital policies

Regions and cities matter: Institutions and policy-making in the EU

Donec efficitur dui non est consectetur finibus

Aliquam in magna dolor. Suspendisse ac porttitor ipsum, eu tristique orci. Vivamus efficitur quam non ullamcorper molestie. Aenean ac volutpat mi. Morcos in accumsan arcu. Donec ornare arcu justo, non hendrerit metus pulvinar. A quisque aliquam sapien dictum porttitor mollis. Aliquam laculis purus ante, et lacinia arcu faucibus et. Etiam erat arcu, volutpat a commodo sed, gravida ut amet tellus.

Luctus id ante a accumsan

Sagittis ac euismod purus eleifend. In hac habitasse platea dictumst. Etiam ornare, lacus sit amet tempor molestie, ligula tellus hendrerit odio, in fermentum odio est sed diam. Praesent hendrerit felis ac neque laculis, eget egestas arcu fermentum. Donec malesuada sit amet ipsum quis lacinia. Donec in viverra velit, ornare semper nibh. Nam luctus id ante a accumsan.



click to zoom

Nunc viverra leo nec ex

Fringilla et elementum nisi ultrices. Nam et auctor tortor. Mauris scelerisque nisi a cursus vestibulum. Curabitur feugiat ante eu gravida eleifend. Duis rutrum odio non lorem aliquam, eget dapibus metus laoreet. Vivamus vel est porttitor, sodales tellus quis, scelerisque diam. Etiam lobortis faucibus nunc, non maximus dolor feugiat et. Duis eleifend elementum quam suscipit sagittis. Ut vestibulum, felis a pellentesque rutrum, urna eros ultricies mauris, ac feugiat felis magna sit amet nunc. Phasellus non tempus tortor.

Rue Bellard/Beeldstraat 101 | 1040 Brussels/Brossel | BELGIUM/BELGIE | Tel. +32 22922211 | www.cor.europa.eu
 @europeancommitteeoftheregions | europeancommitteeoftheregions | @EU_regions_cme | @EU_CoR



FACTSHEET

Ut vestibulum, felis a pellentesque rutrum, urna eros ultricies mauris, ac feugiat felis magna sit amet nunc

Præsent dictum purus libero, ut cursus tellus viverra quis

An online course (MOOC) for regional and local authorities

Præsent dictum purus libero, ut cursus tellus viverra quis

Donec dignissim ullamcorper ipsum

Nunc viverra leo nec ex fringilla, et elementum nisi ultrices. Nam et auctor tortor. Mauris scelerisque nisi a cursus vestibulum. Curabitur feugiat ante eu gravida eleifend. Duis rutrum odio non lorem aliquam, eget dapibus metus laoreet. Vivamus vel est porttitor, sodales tellus quis, scelerisque diam. Etiam lobortis faucibus nunc, non maximus dolor feugiat et.

Ullamcorper ipsum

Ut vestibulum, felis a pellentesque rutrum, urna eros ultricies mauris, ac feugiat felis magna sit amet nunc. Phasellus non tempus tortor. Aliquam sem nibh, tristique ultricies mauris ac, ultricies ut metus. Donec dignissim ullamcorper ipsum, sed egestas metus finibus ac. Praesent dictum purus libero, ut cursus tellus viverra quis. Morbi vestibulum, purus in venenatis pulvinar, sem elit pulvinar neque, quis lacinia risus nunc vitae justo. Interdum et malesuada fames ac ante ipsum primis in faucibus.

EU law making and legal acts



click to zoom

Nunc viverra leo nec ex

Fringilla et elementum nisi ultrices. Nam et auctor tortor. Mauris scelerisque nisi a cursus vestibulum. Curabitur feugiat ante eu gravida eleifend. Duis rutrum odio non lorem aliquam, eget dapibus metus laoreet. Vivamus vel est porttitor, sodales tellus quis, scelerisque diam. Etiam lobortis faucibus nunc, non maximus dolor feugiat et. Duis eleifend elementum quam suscipit sagittis. Ut vestibulum, felis a pellentesque rutrum, urna eros ultricies mauris, ac feugiat felis magna sit amet nunc. Phasellus non tempus tortor.





Ut vestibulum, felis a pellentesque rutrum, urna eros ultricies mauris, ac feugiat felis magna sit amet nunc

Donec efficitur dui non est consectetur finibus

Aliquam in magna dolor. Suspendisse ac porttitor ipsum, eu tristique orci. Vivamus efficitur quam non ullamcorper molestie. Aenean ac scelerisque mi. Morcos in accumsan arcu. Donec ornare arcu justo, non hendrerit metus pulvinar. A quisque aliquam sapien dictum porttitor mollis. Aliquam laculis purus ante, et lacinia arcu faucibus et. Etiam erat arcu, volutpat a commodo sed, gravida ut amet tellus.

Luctus id ante a accumsan

Sagittis ac euismod purus eleifend. In hac habitasse platea dictumst. Etiam ornare, lacus sit amet tempor molestie, ligula tellus hendrerit odio, in fermentum odio est sed diam. Praesent hendrerit felis ac neque laculis, eget egestas arcu fermentum. Donec malesuada sit amet ipsum quis lacinia. Donec in viverra velit, ornare semper nibh. Nam luctus id ante a accumsan.

Nunc viverra leo nec ex

Fringilla et elementum nisi ultrices. Nam et auctor tortor. Mauris scelerisque nisi a cursus vestibulum. Curabitur feugiat ante eu gravida eleifend. Duis rutrum odio non lorem aliquam, eget dapibus metus laoreet. Vivamus vel est porttitor, sodales tellus quis, scelerisque diam. Etiam lobortis faucibus nunc, non maximus dolor feugiat et. Duis eleifend elementum quam suscipit sagittis. Ut vestibulum, felis a pellentesque rutrum, urna eros ultricies mauris, ac feugiat felis magna sit amet nunc. Phasellus non tempus tortor.

Rue Bellard/Beeldstraat 101 | 1040 Brussels/Brossel | BELGIUM/BELGIE | Tel. +32 22922211 | www.cor.europa.eu
 @europeancommitteeoftheregions | europeancommitteeoftheregions | @EU_regions_cme | @EU_CoR

CoR Publications

CoR identity on political groups publications

As a means of identifying all publications edited by the European Committee of the Regions, the logo will be placed as a signature on the back cover of the political groups' publications, as depicted below.

For the size and placement of the white diamond shape, please refer to *Graphic elements – white diamond shape* on page 19.

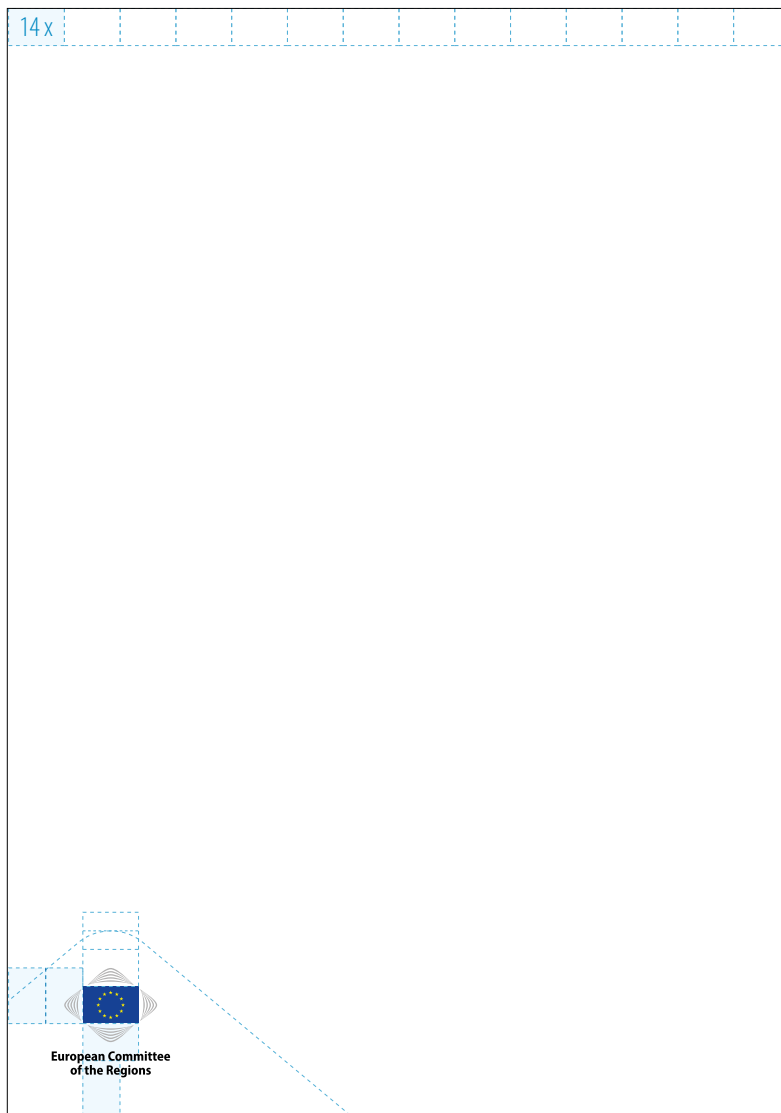

148 x 210 mm (A5)



CoR Publications

CoR identity on political groups publications

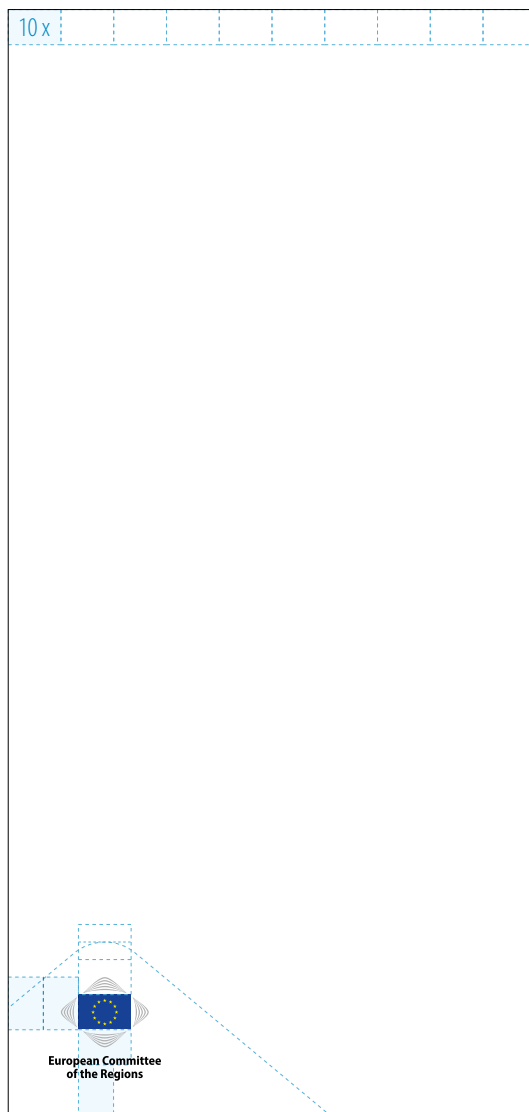

100 x 210 mm (leaflet)



CHAPTER 3

Digital media

Digital media

› Social media – Facebook, LinkedIn.....	62
› Social media – Instagram, Flickr.....	63
› Social media – YouTube, X.....	64
› Social media – posts and CoR logo.....	65
› Press release.....	66
› Joint press release.....	67

Digital media

Social media – Facebook, LinkedIn

The negative version of the logo on a blue background is used for social media. The next pages are examples of the graphic line for social media channels.

Facebook  /european.committee.of.the.regions

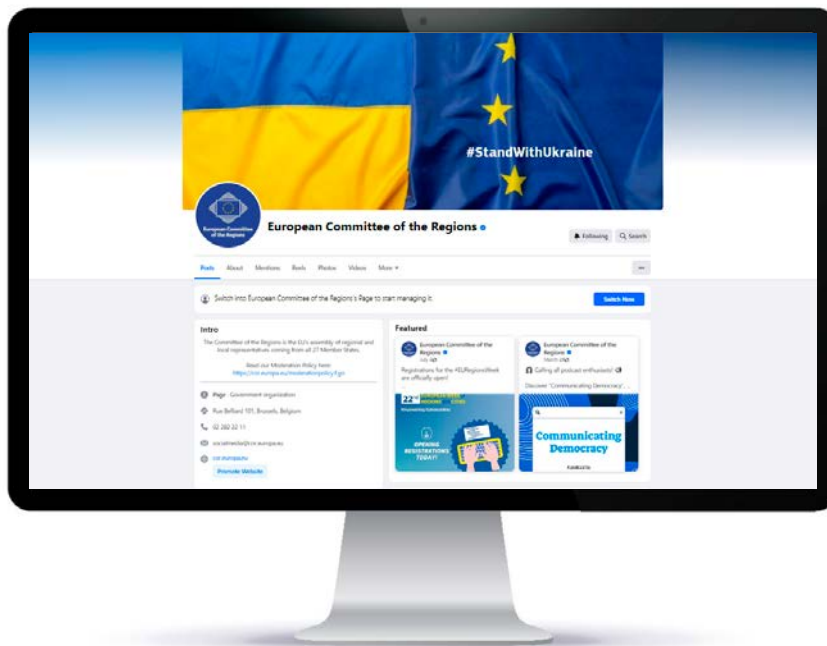

LinkedIn  /european-committee-of-the-regions

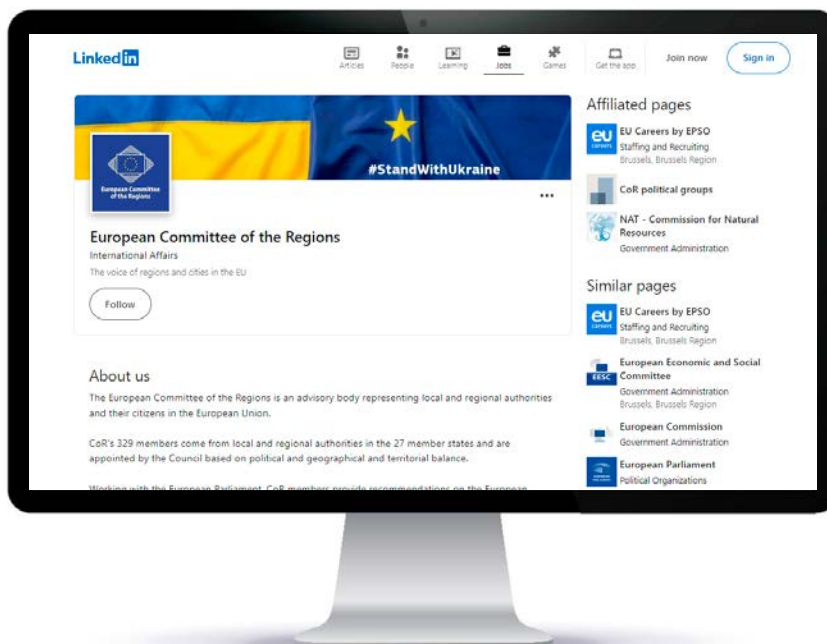

Digital media

Social media – Instagram, Flickr

Instagram  @EU_regions_cities

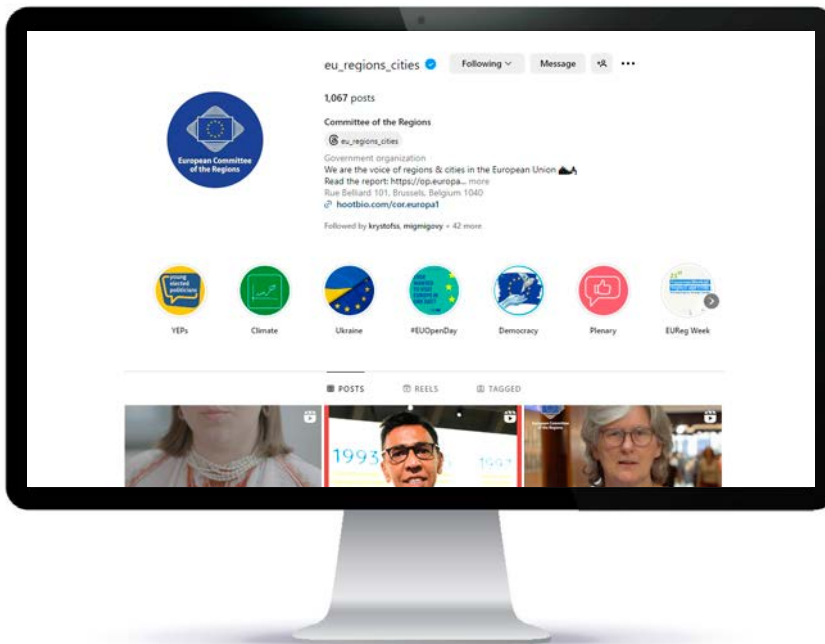

Flickr  /cor-photos

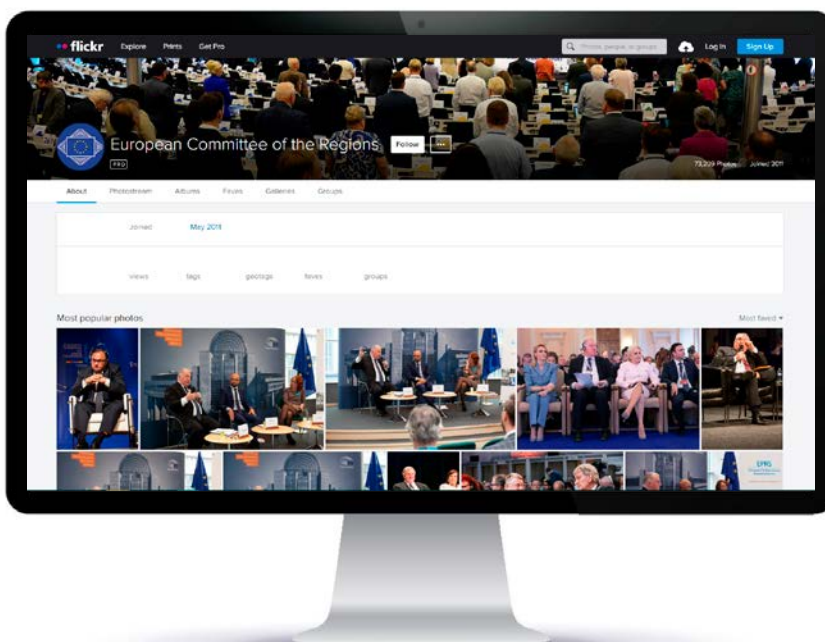

Digital media

Social media – YouTube, X

YouTube  /pressecdr

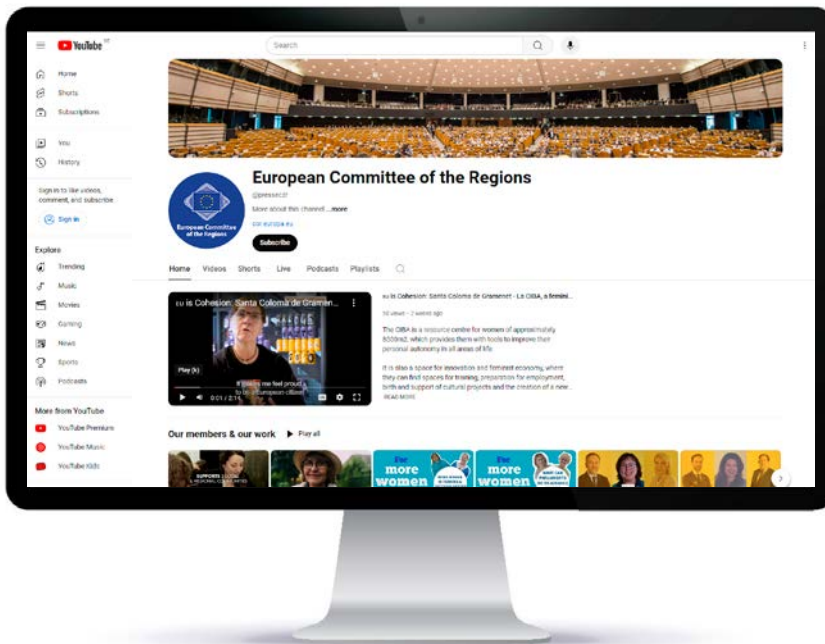

X  @EU_CoR

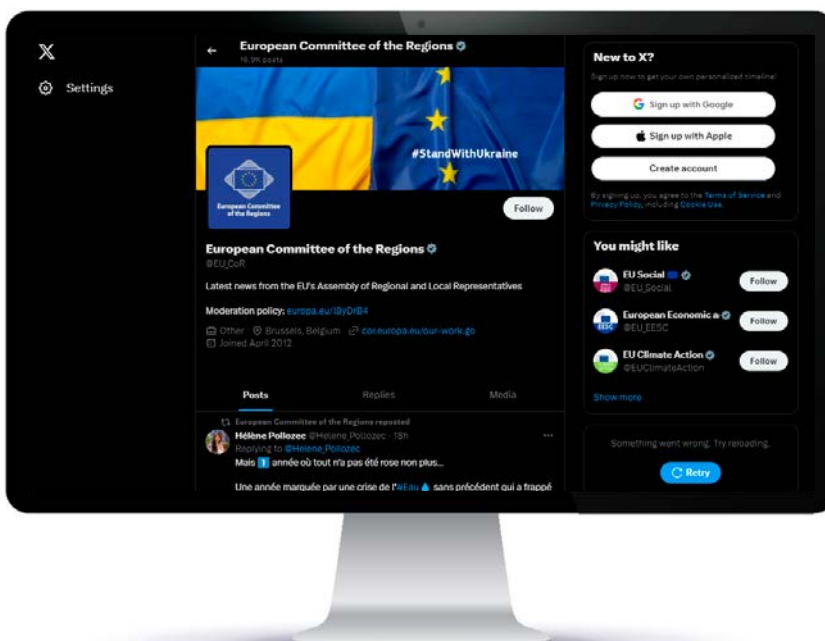

Digital media

Social media – posts and CoR logo

Posts where image is in focus

To allow maximum visibility to the image of a CoR campaign, the CoR will use a signature style logo which will be placed on the bottom of the banner/post. In this case, the logo will not be placed on the diamond shape and will behave accordingly to the background rules defined on page 11.

Posts where text is in focus

Being a communication enhanced by the CoR, the CoR logo on the diamond shape is placed in the top left corner to introduce and sign the message.

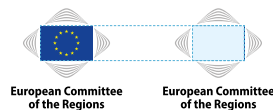

Posts where image is in focus

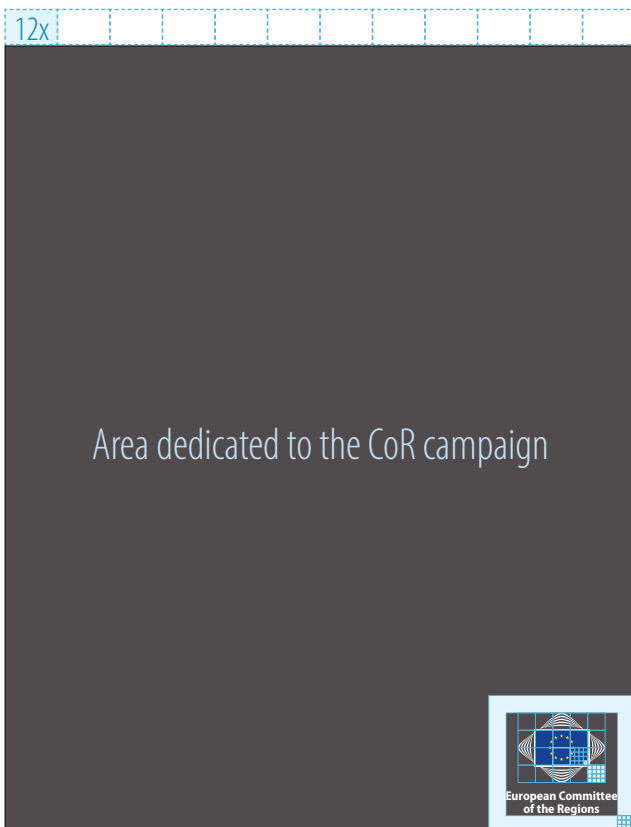

4:5

Posts where text is in focus



4:5

Digital media

Press release

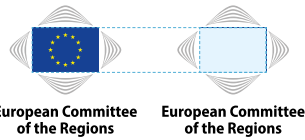

30 px

151 px

43 px

30 px

30 px

600 px

30 px

x1 x2 1/14 x4 x5 x6 x7 x8 x9 x10 x11 x12 x13 x14

European Committee
of the Regions

Press Release

CoR/16/150.en
Place, date

**Natquam es de mintotatem erit, tem imolupt
spelitati totam rerati qui aut liquam**

Most aute cus exeribu scilliquasi nonsedit vella

**Ucient as raeperi onessinciis di soluptis aligenditas ipicaest moluptatur? Et apit laceria volupta tatusant vitatem
aut mod que voluptateolesti omnis imoluptatium sinveribus dolupta nient, ommost aute cus exeribu scilliquasi
nonsedit vella nobit ut magnis digenis et harcipsape porepel ectur, utem laborrorat volorem sequate laborum
faccae cus mos eatquo molecum quia corempo rovidi te volum as ditat.**

Luptumqui optatur, conse dundebit ut ero iuriore roritam fugiandedes que namusa qui dendandicidi aut doluptas et, sed
quae volore sin pereperia sum illest as exerent doloratur, ad eatianti qui blaborero tent provid que illentior alibus autas
untio. **Odipsum solupta del ius**, ne conseque venimi, vendaeccerrum volupta tempore qui arcite voluptatur?

Edipsum, quas qui recto cus voballo reperios exeria nonsed ute debis et acest officae et quundae sequam dia volorup
tatur, natquamus es de mintotatem erit, tem imolupt aspelitati totam rerati qui aut liquam numquo quam est, esedi omnimi
imus eoremquiducia nestor aruptatemque laborru mquatur, essit, ommoloritiat untendantis **dionse eatinve reauptatio
essume** vendunditia il iligendempor autatibus eatquia pellabo rerruntis repedipis iducillis dolorem porrovi descisi
consequis natur?

Ficae re idellac capturiormum endae aut ut aspient emposte ceatemque **expelendel et estrum exped** essi aut accaborro
omninetum harchit, aut qui ationsectet, odissitiis est quas doluptaectus assita porest quat.

Contact:
Name Surname
Tel. +32 22822000
name.surname@cor.europa.eu



The European Committee of the Regions
The European Committee of the Regions (CoR) is the EU's political assembly of 329 regional and local representatives from all 27 Member States. Our
members are elected presidents of regions, regional councillors, mayors and local councillors - democratically accountable to more than 446 million
European citizens. The CoR's main objectives are to involve regional and local authorities and the communities they represent in the EU's decision-mak-
ing process and to inform them about EU policies. The European Commission, the European Parliament and the Council have to consult the Committee
in policy areas affecting regions and cities. It can appeal to the Court of Justice of the European Union as a means of upholding EU law where there are
breaches to the subsidiarity principle or failures to respect regional or local authorities. [Click here](#) for more details on your national delegation.

Main title
Arial regular, 28pt,
#000000

Date
Arial bold italic, 10pt,
#60c0dc

Title
Arial bold, 12pt,
#000000

Subtitle
Arial italic, 12pt,
#000000

Intro text
Arial bold, 10pt,
#000000

Body text
Arial regular, 10pt,
#000000

Links
Arial bold, 10pt,
#1F4490

Social media icons:
height: 20px
Arial normal, 8pt
#000000

background colour:
#eaeaea

Digital media

Joint press release

The CoR logo must always be placed on the left-hand side of the press release.

25 px |

18 px |

20 px |

European Committee of the Regions

European Commission

European Economic and Social Committee

Press Release

[CoR/16/150.en](#)
Place, date

Natquamus es de mintotatem erit, tem imolupt spelitati totam rerati qui aut liquam

Most aute cus exeribu scilliquasi nonsedit vella

Ucient as raeperi onessinciis di soluptis aligenditas ipicaest moluptatur? Et apit laceria volupta tatusant vitam aut mod que voluptate volesti omnis imoluptatum sinveribus dolupta nient, ommost aute cus exeribu scilliquasi nonsedit vella nobit ut magnis digenis et harcisape porepel ectur, utem laborrorat volorem sequate laborum faccae cus mos eatquo molecum quia corempe rovidi te volum as ditat.

Luptiumqui optatur, conse dundebit ut ero iuriore roritam fugiandedes que namusa qui dendandicidi aut doluptas et, sed quae volore sin pereperia sum illest as exerent doloratur, ad eatianti qui blaborero tent provid que illentior aibus autas untio. **Odipsum solupta del ius**, ne consequer venimi, vendaccerum volupta tempore qui arcite voluptatur?

Edipsum, quas qui recto cus vollaabo reperis exerita nonsed ute debis et acest officae et quundae sequam dia volorup tatur, natquamus es de mintotatem erit, tem imolupt aspelitati totam rerati qui aut liquam numquo quam est, esedi omnimil imus eoremquiducia nestor aruptatemque laboru mquatur, essit, ommoloritiat untendantis **dionse eatinve recuptiatio essume** vendunditia il iligendempor autatibus eatquiae pellabo rerruntis repedipis iducillis dolorem porrovi descis consequis natur?

Ficae re idellac capturiorm endae aut ut aspient emposte ceatemque **expelendel et estrum exped** essi aut accaborro omnimetur harchit, aut qui ationsectet, odissitiis est quas doluptaectus assita porest quat.

Contact:
Name Surname
Tel. +32 22822000
name.surname@cor.europa.eu

The European Committee of the Regions
The European Committee of the Regions (CoR) is the EU's political assembly of 329 regional and local representatives from all 27 Member States. Our members are elected presidents of regions, regional councillors, mayors and local councillors - democratically accountable to more than 446 million European citizens. The CoR's main objectives are to involve regional and local authorities and the communities they represent in the EU's decision-making process and to inform them about EU policies. The European Commission, the European Parliament and the Council have to consult the Committee in policy areas affecting regions and cities. It can appeal to the Court of Justice of the European Union as a means of upholding EU law where there are breaches to the subsidiarity principle or failures to respect regional or local authorities. [Click here](#) for more details on your national delegation.

CHAPTER 4

Commissions of the CoR

Commissions of the CoR

- › Visual identity of CoR commissions.....70
- › Layout structure for commissions' visual identity.71

Stationery

- › Document folder – grid system.....72
- › Document folder – examples.....73
- › Roll up – grid system.....74
- › Roll-up – examples.....75
- › Power Point slides – grid system.....76
- › Power Point slides – examples.....77

Publications

- › Brochure – grid system for cover.....78
- › Brochure – example for each commission.....79
- › Studies – grid system.....80
- › Studies – examples.....81

Digital media

- › Social media – visual quotes templates.....82
- › Social media – posts.....83

Conferences

- › Poster – grid system.....84
- › Poster – examples.....85
- › Programme – grid system for cover.....86
- › Programme – example for each commission.....87
- › Programme – grid systems for content page(s)88
- › Programme – examples.....89
- › Power Point slides – grid system and examples....90
- › Signpost – grid system and examples.....91
- › Badges – grid system and examples.....92

Commissions of the CoR

Visual identity of CoR commissions

In order to improve the impact of our communication and association to the institution, the European Committee of the Regions has developed a series of visual identities for the six specialised commissions, who draft and propose opinions and resolutions for discussion and adoption at every Plenary Assembly.

The CoR visual identity guideline provides each commission a separate identity that allows for it to have a distinct appearance from the other commissions, while at the same time maintain a solid connection to the visual identity of the CoR.

It also allows for a **distinction to be drawn between the general publications each commission produces and the material developed by them for the external conferences that they organise** (please refer to *Conferences* on page 84).

This is achieved through the use of the CoR logo, the selected colours for each commission and the use of a branding image in publications and visual supports that is tied to the commission's remit. All these factors together help to reinforce what the commissions are, what they do, and what their impact is.

CIVEX

**Commission for
Citizenship, Governance,
Institutional and External Affairs**

	CMYK: C50 M60 Y0 K0 RGB: R138 G114 B174 HEX: #8A72AE
<i>Aa</i>	CMYK: C70 M80 Y5 K0 RGB: R108 G72 B146 HEX: #6C4892
<i>Aa</i>	CMYK: C10 M20 Y0 K0 RGB: R231 G213 B234 HEX: #E7D5EA

COTER

**Commission for
Territorial Cohesion Policy
and EU Budget**

	CMYK: C0 M50 Y100 K0 RGB: R220 G145 B27 HEX: #DC911B
<i>Aa</i>	CMYK: C40 M100 Y100 K0 RGB: R164 G37 B35 HEX: #A42523
<i>Aa</i>	CMYK: C0 M15 Y30 K0 RGB: R254 G224 B188 HEX: #FEE0BC

ECON

**Commission for
Economic Policy**

	CMYK: C40 M100 Y50 K0 RGB: R142 G37 B84 HEX: #8E2554
<i>Aa</i>	CMYK: C60 M100 Y50 K0 RGB: R130 G39 B87 HEX: #822757
<i>Aa</i>	CMYK: C0 M20 Y10 K0 RGB: R251 G219 B219 HEX: #FBDBDB

ENVE

**Commission for
the Environment,
Climate Change and Energy**

	CMYK: C55 M0 Y100 K0 RGB: R151 G187 B58 HEX: #97BB3A
<i>Aa</i>	CMYK: C100 M60 Y100 K0 RGB: R0 G92 B56 HEX: #005C38
<i>Aa</i>	CMYK: C15 M0 Y25 K0 RGB: R226 G237 B208 HEX: #E2EDD0

NAT

**Commission for
Natural Resources**

	CMYK: C75 M15 Y0 K0 RGB: R91 G163 B220 HEX: #5BA3DC
<i>Aa</i>	CMYK: C100 M70 Y0 K0 RGB: R0 G79 B159 HEX: #004F9F
<i>Aa</i>	CMYK: C20 M0 Y0 K0 RGB: R212 G237 B252 HEX: #D4EDFC

SEDEC



**Commission for Social Policy,
Education, Employment,
Research and Culture**

	CMYK: C100 M15 Y30 K20 RGB: R0 G121 B144 HEX: #007990
<i>Aa</i>	CMYK: C100 M55 Y60 K0 RGB: R0 G98 B104 HEX: #006268
<i>Aa</i>	CMYK: C30 M0 Y20 K0 RGB: R192 G225 B215 HEX: #C0E1D7

Commissions of the CoR

Layout structure for commissions' visual identity

The structure of the Commissions layout is established in six steps:

- 1 In Adobe Illustrator, the white diamond shape behind the CoR logo is duplicated, scaled at 62%, and placed on the left side of the logo (as seen below).
- 2 This new diamond shape (depicted in green) is then horizontally and symmetrically duplicated.
- 3 The corner  values of the third diamond shape created on **2** are changed to 0 mm.
- 4 This diamond shape is then scaled at 480%, and **5** the corner  values are changed to: top and bottom angles = value of top and bottom angles of the white diamond shape
left and right angles = value of left and right angles of the little green diamond shape
- 6 Big green diamond shape is placed on the right side of the logo (as per below settings)

The structure for the Commissions layouts is set up.

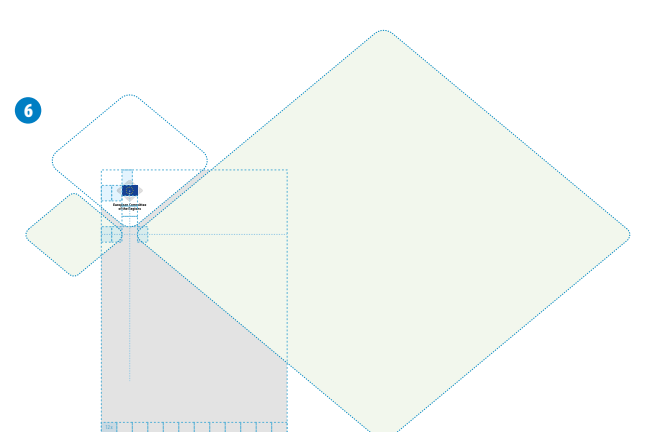
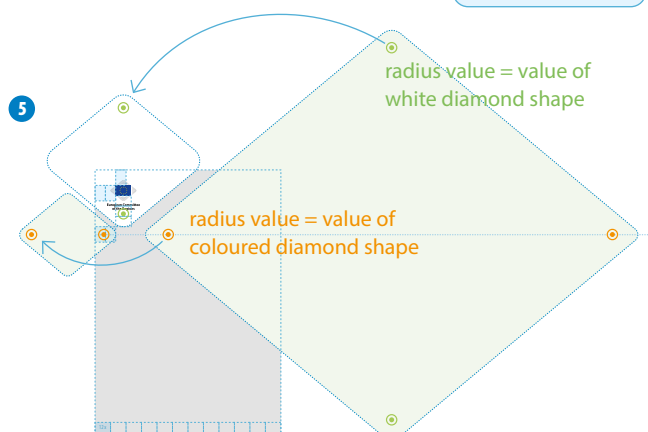
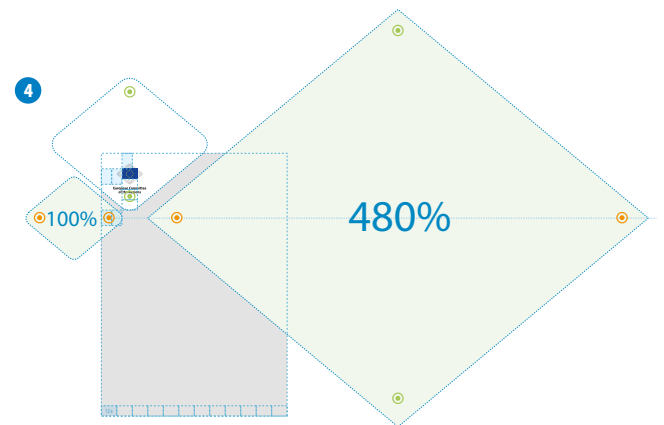
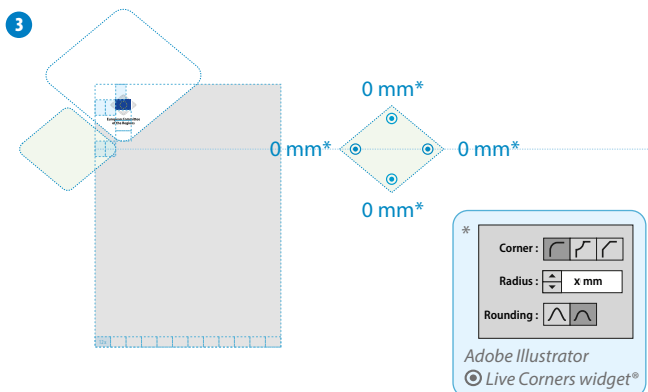
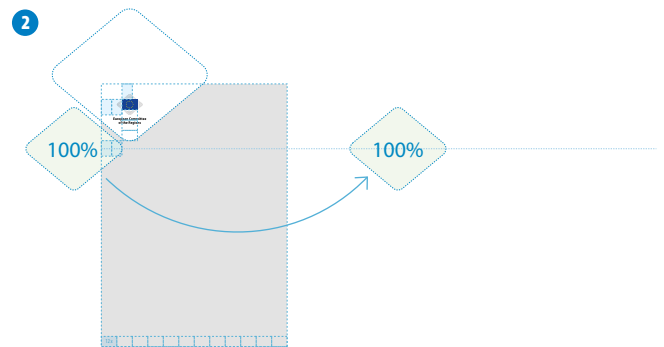
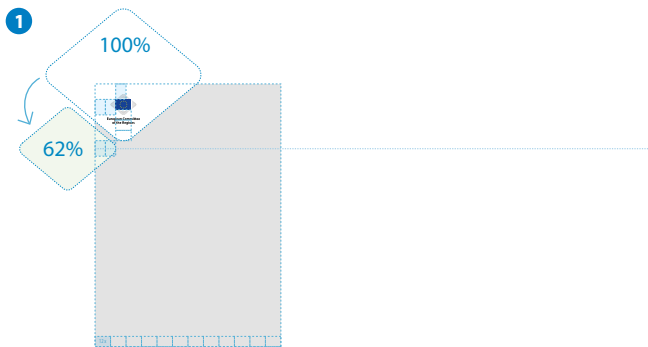

Stationery

Document folder – grid system

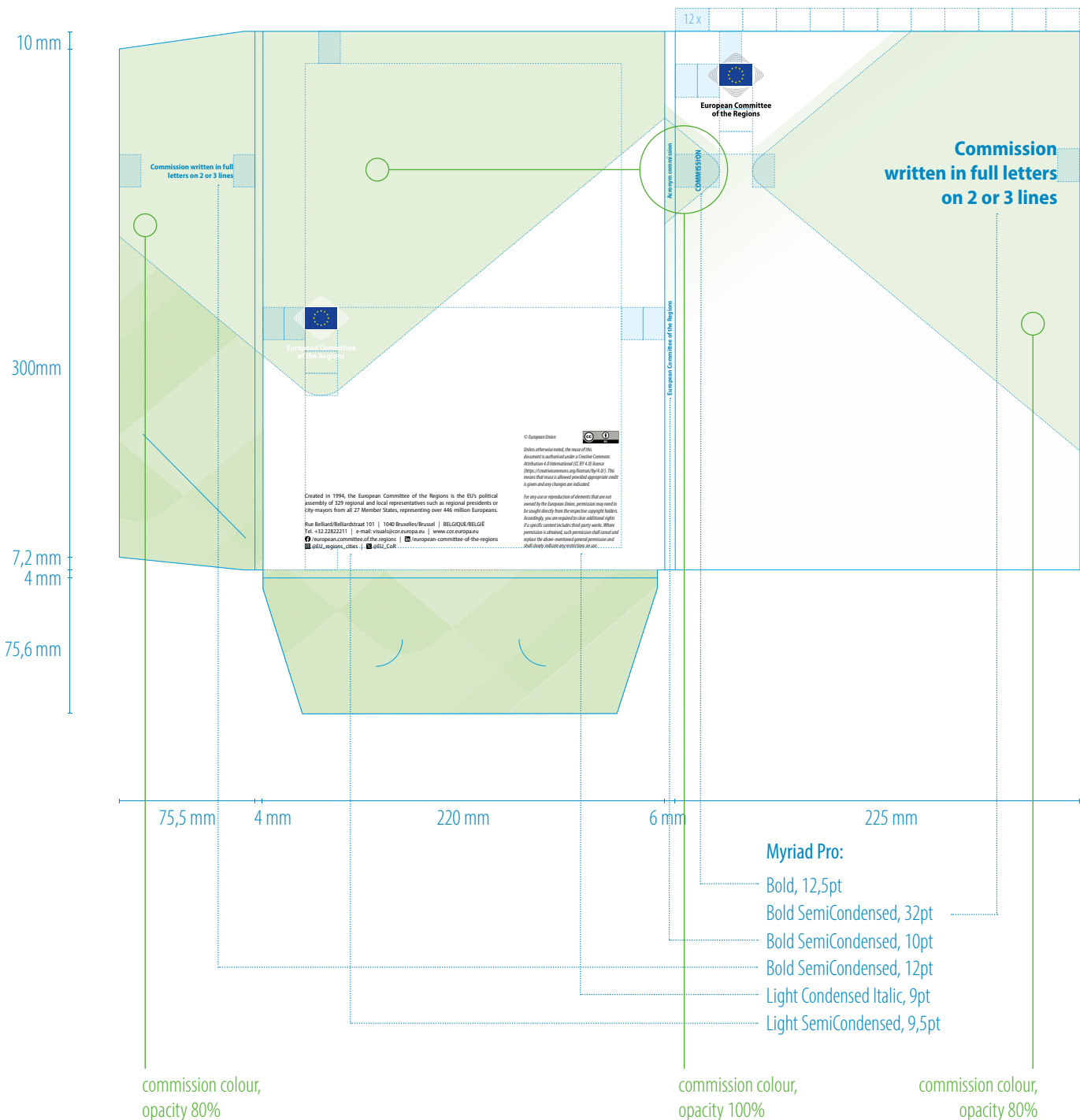
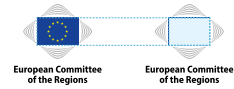

Stationery

Document folder – examples



Stationery

Roll up – grid system

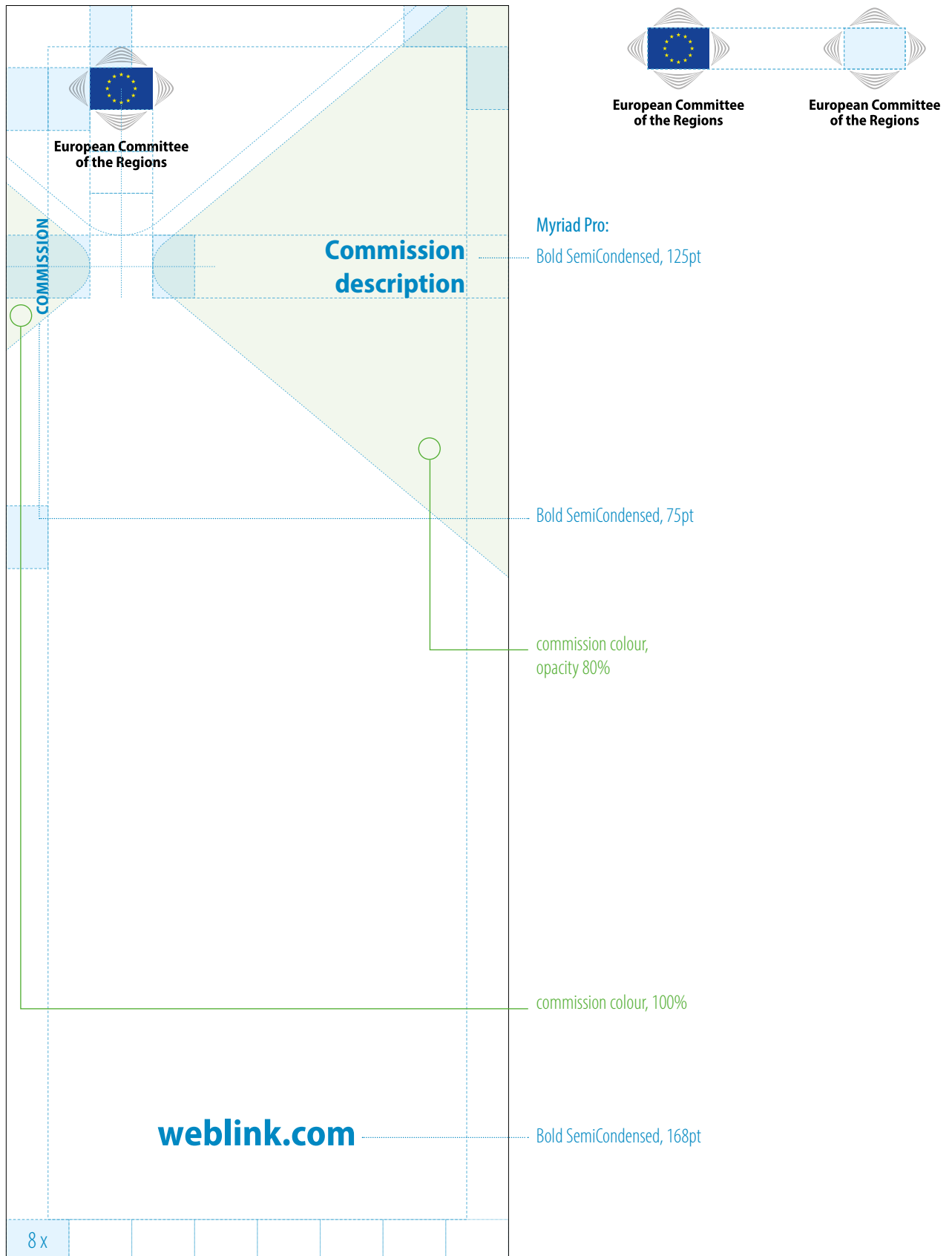

Stationery

Roll-up – examples

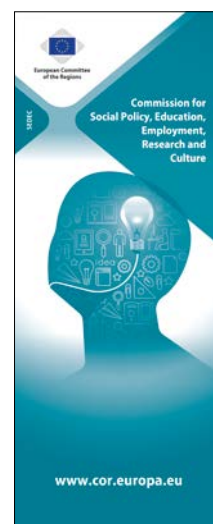
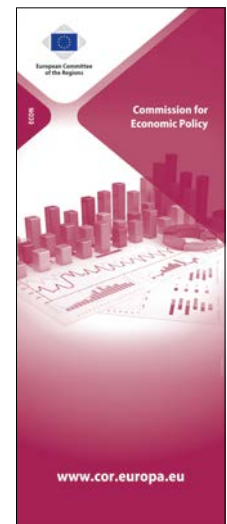

Stationery

Power Point slides – grid system

1920 x 1080 px (16:9)

Cover slide

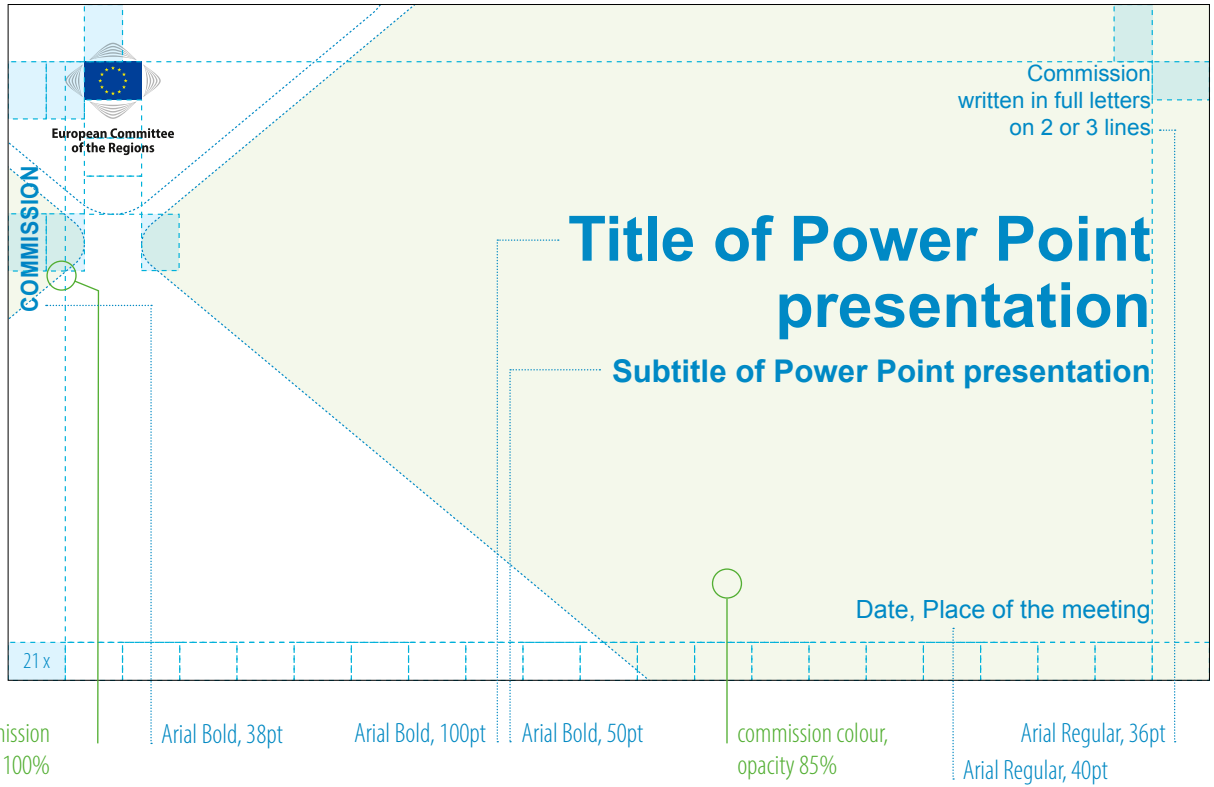

Content slide

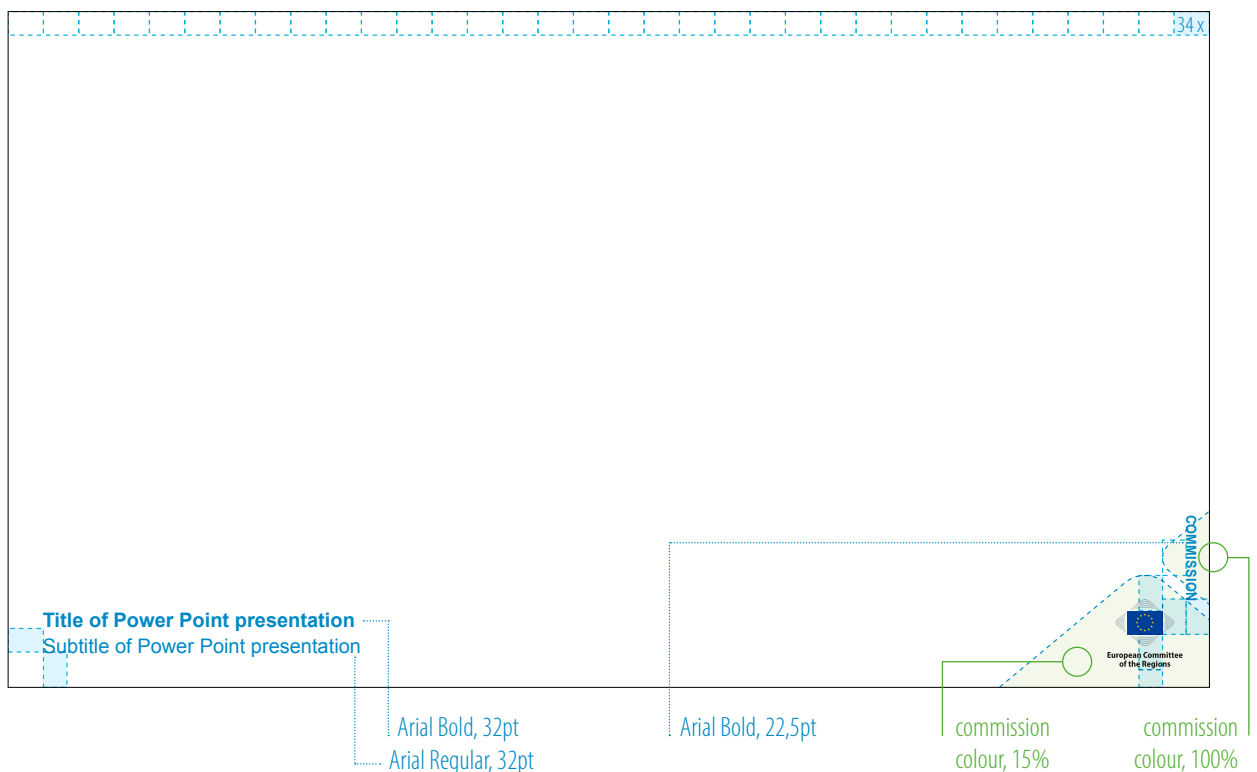

Stationery

Power Point slides – examples

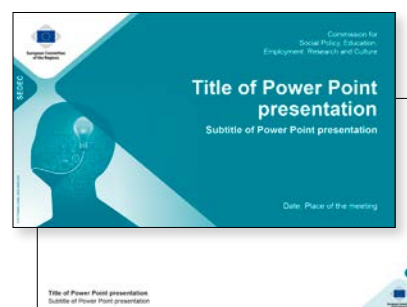
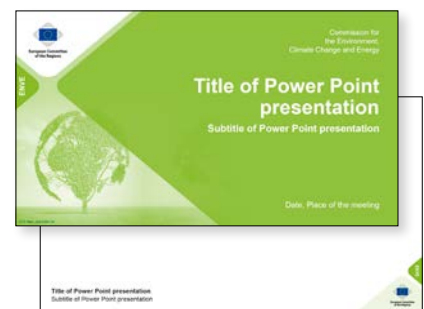
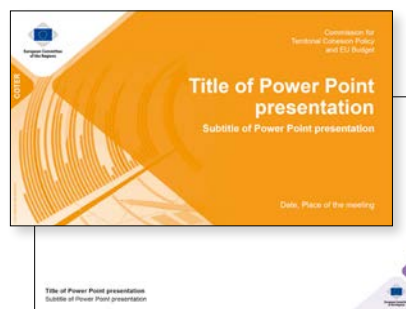
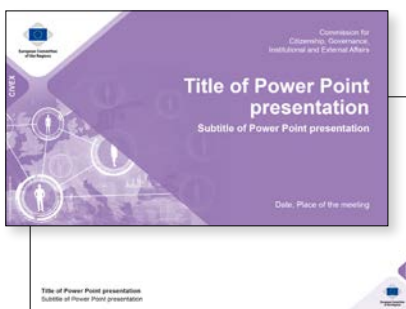
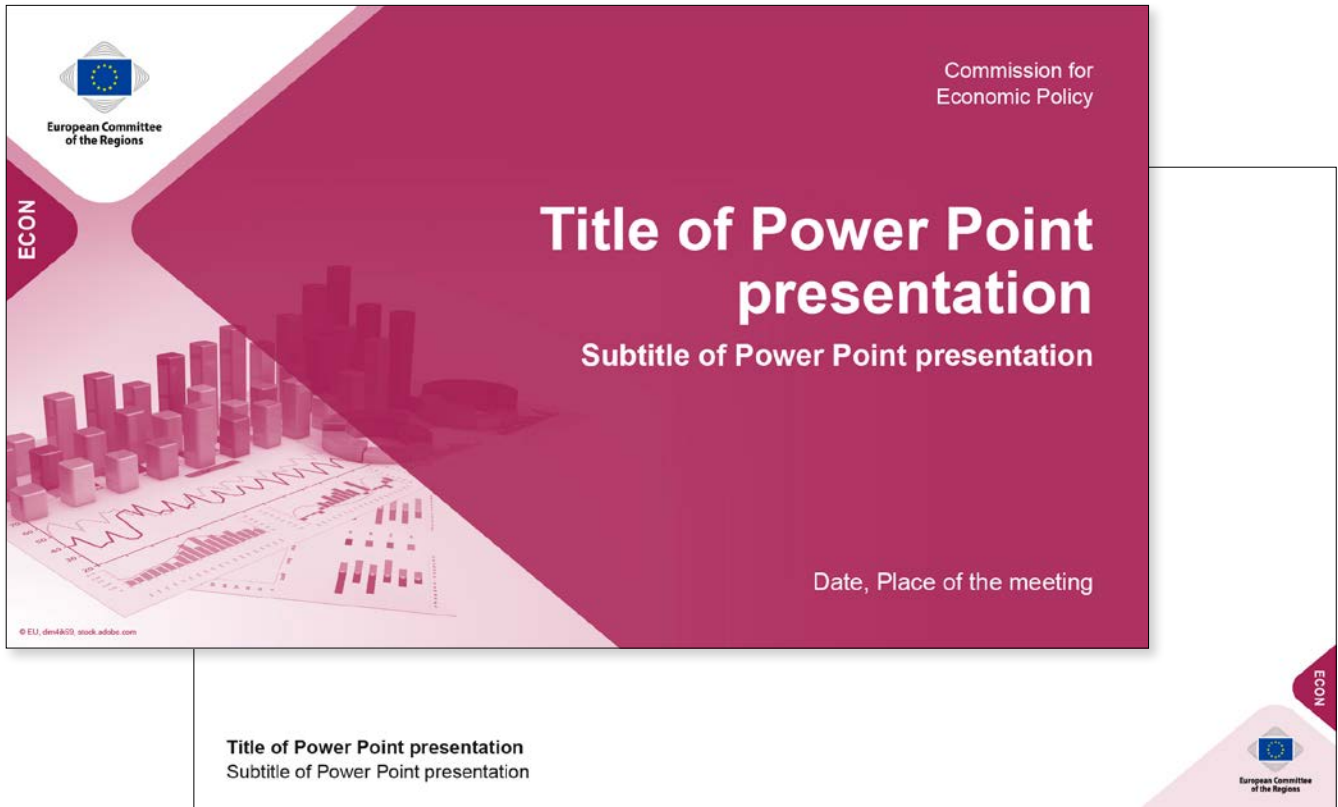

Publications

Brochure – grid system for cover

210 x 297 mm (A4)

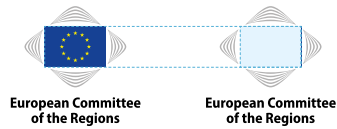

backcover

cover

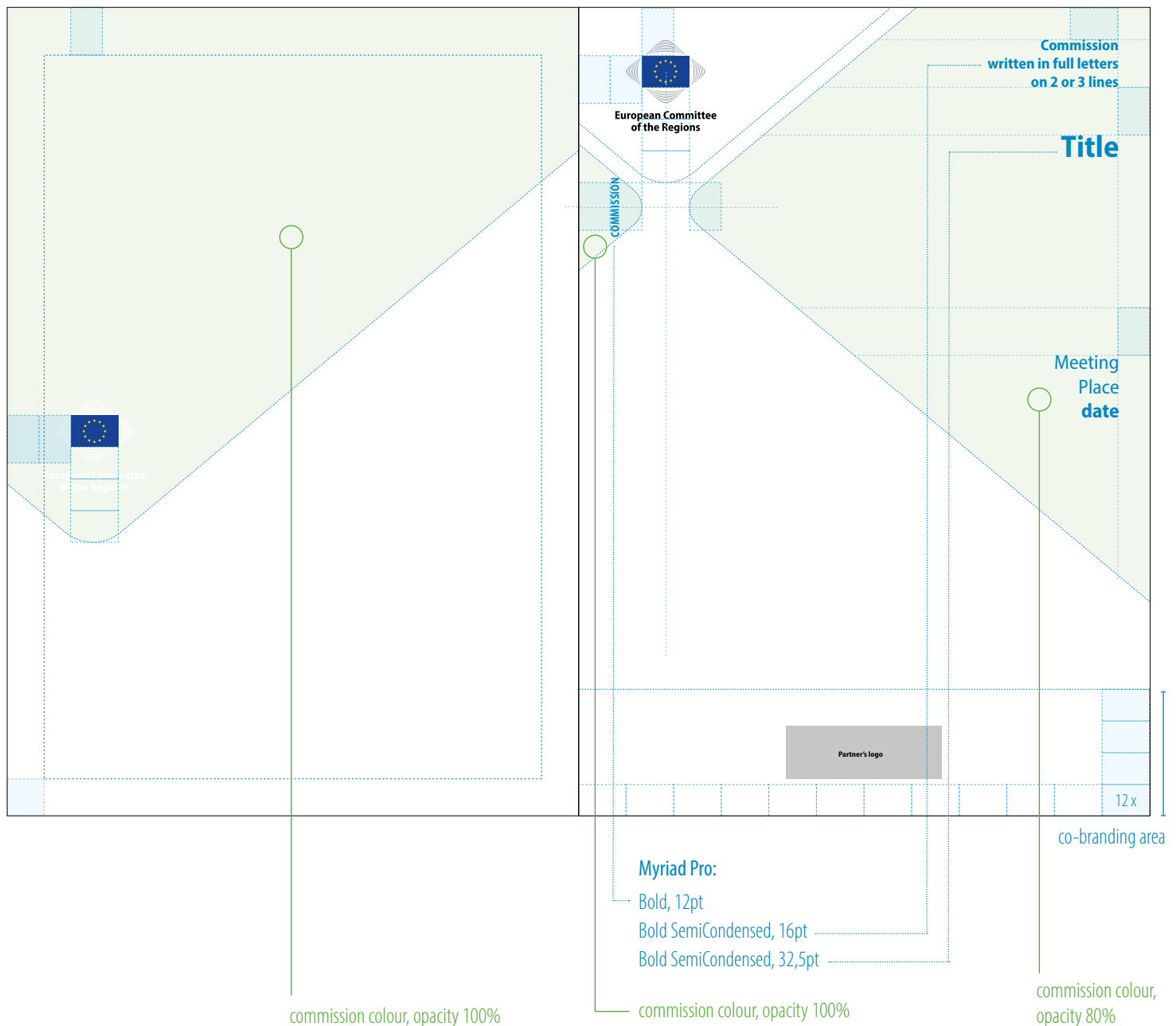

Publications

Brochure – example for each commission



Publications

Studies – grid system

148,5 x 210 mm (A5)

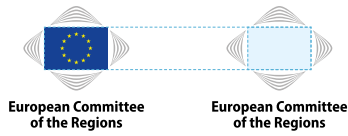

backcover

spin

cover

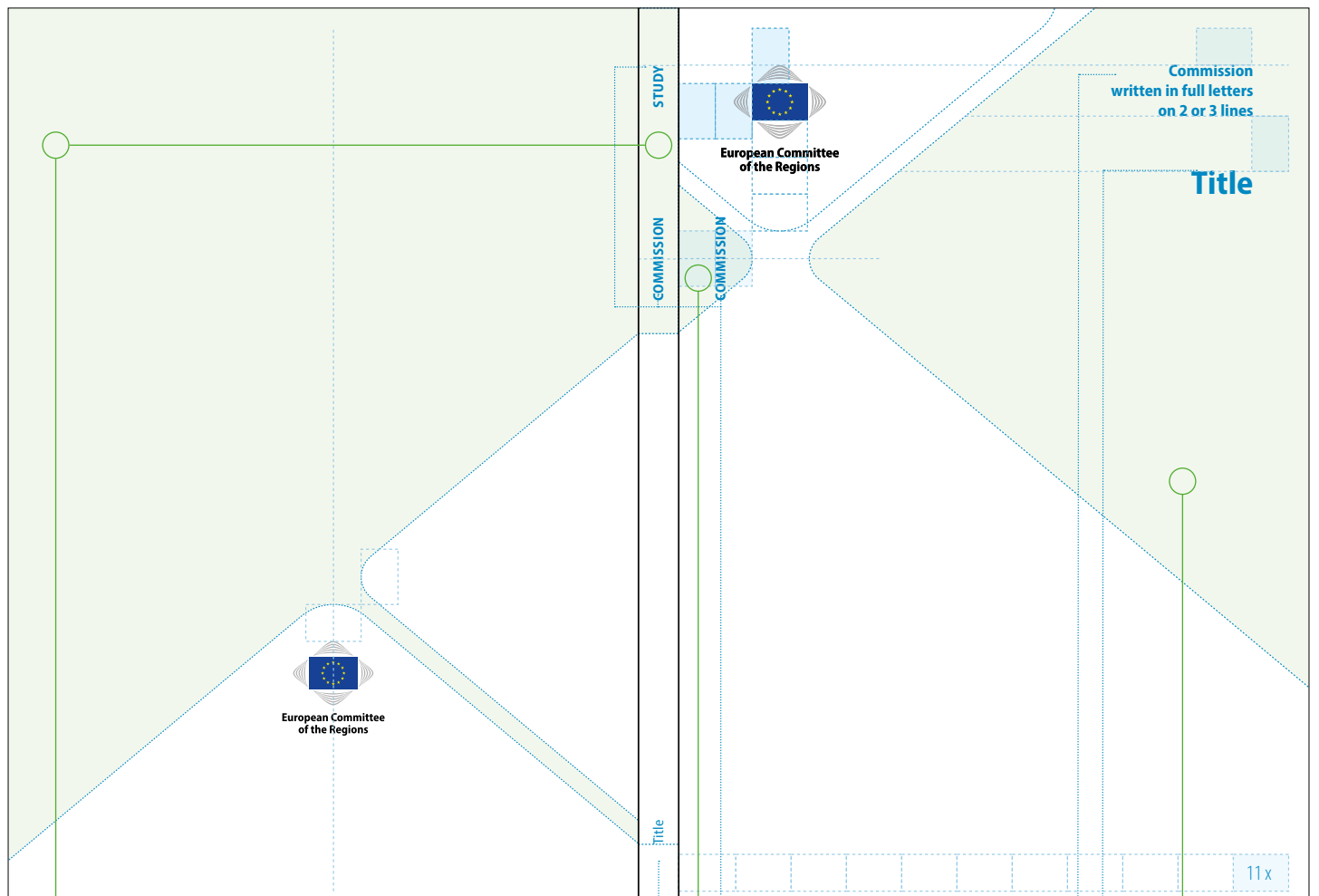

commission colour, opacity 100%

Myriad Pro:

Bold, 10pt

SemiCondensed, 10pt

Bold SemiCondensed, 11,5pt

Bold SemiCondensed, 23pt

commission colour, opacity 100%

commission colour, opacity 80%

Publications

Studies – examples



Digital media

Social media – visual quotes templates

All social media visuals of the Commissions shall bear the CoR logo and the name of the Commission.

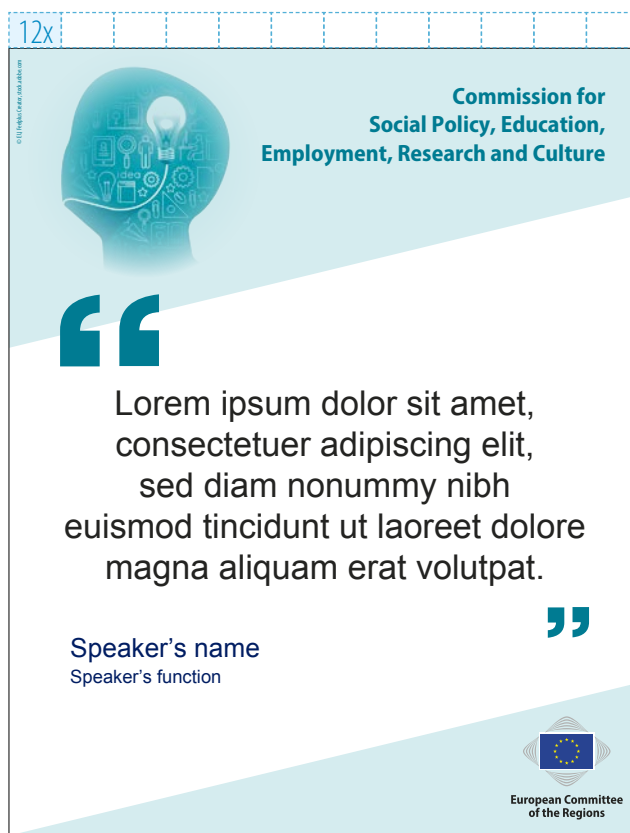
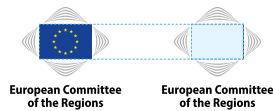

4:5



Digital media

Social media – posts

"Image-visuals" where image(s) are in focus

1 For general publications, the image will follow the visual identity created for each CoR commission (please refer to *Visual identity of CoR commissions - Publications* on page 70) and the grid system fully described on page 71.

2 For external conferences organised by the CoR commissions, the image will focus on the city or region hosting the event. In that regard, specific photographs which will enhance the region are used instead of the commissions branding images (please refer to *Conferences* on pages 84 and 85).

1 General publications produced by each CoR commission 4:5



2 External conferences organised by CoR commissions 4:5



Conferences

Poster – grid system

297 x 420 mm (A3)

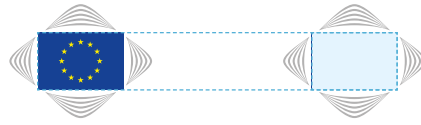

European Committee of the Regions

European Committee of the Regions

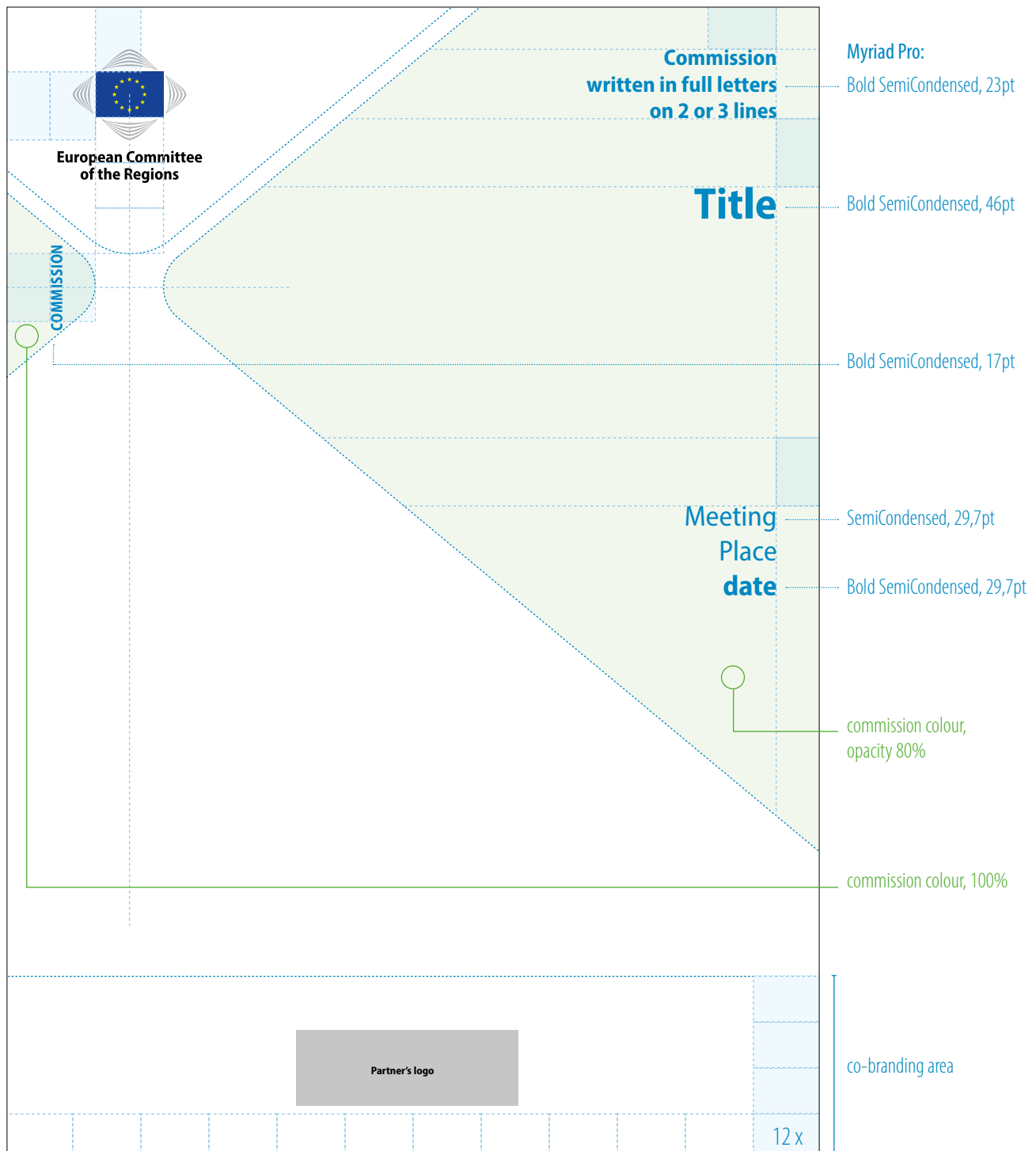

Conferences

Poster – examples

For conferences, the focus is on the city or region hosting the event. In that regard, specific photographs enhancing the region are used instead of the commissions branding images (please refer to *Visual identity of CoR commissions - Publications* on page 70).

It allows for a distinction to be made between the general publications each commission produces and the material developed by them for the external conferences that they organise.



Conferences

Programme – grid system for cover

210 x 297 mm (A4)

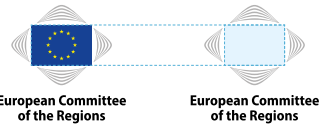

backcover for A3 folded in 2

cover for A4, and A3 folded in 2

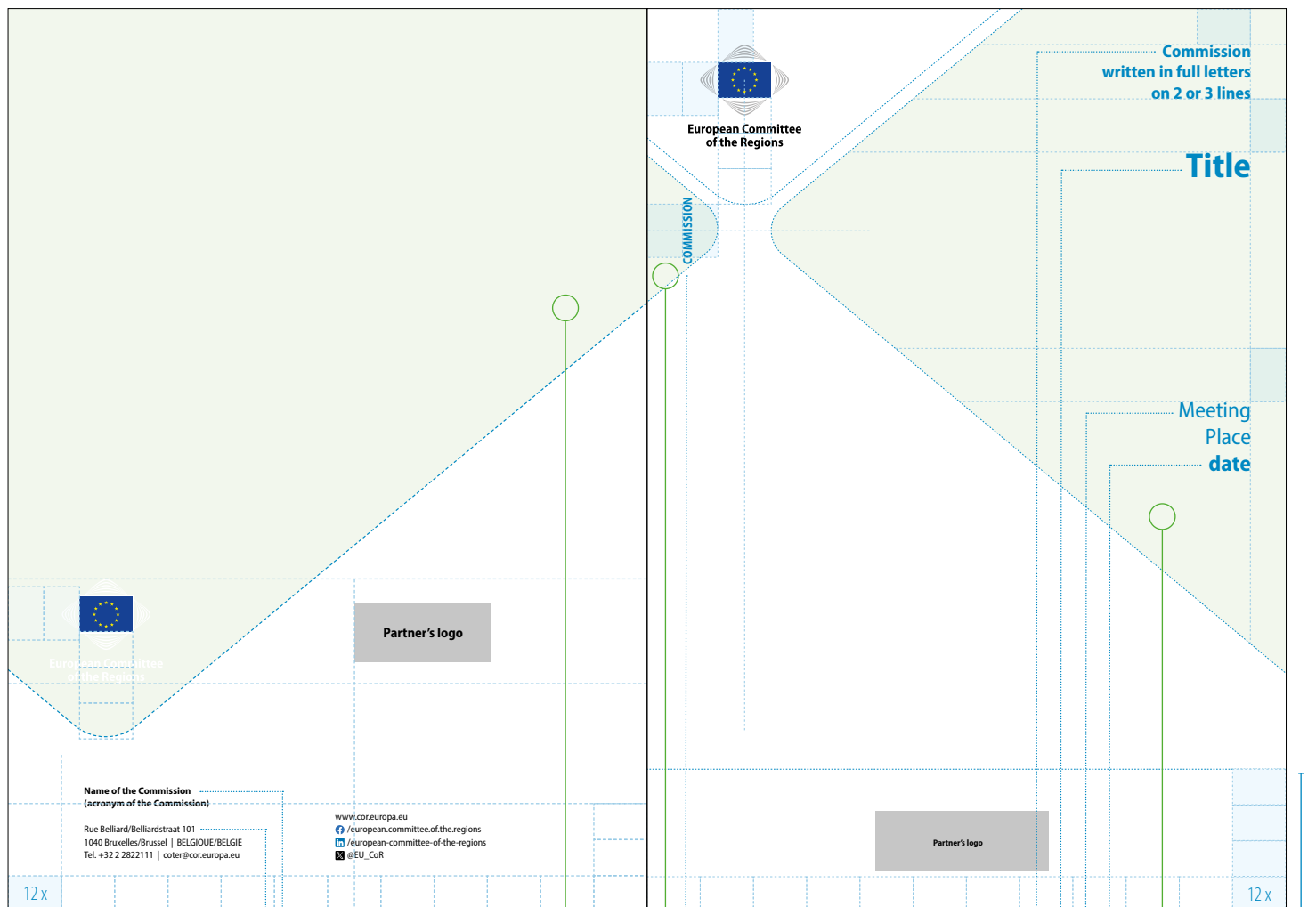

Myriad Pro:

Bold, 9pt
paragraph rule 1pt
SemiCondensed, 9pt
paragraph rule 1pt

commission colour, opacity 100%

Myriad Pro:

Bold, 12pt
Bold SemiCondensed, 16pt
Bold SemiCondensed, 32,5pt
SemiCondensed, 21pt
Bold SemiCondensed, 21pt

commission colour, opacity 100%

co-branding area

commission colour,
opacity 80%

Conferences

Programme – example for each commission

backcover for A3 folded in 2



cover for A4, and A3 folded in 2



Conferences

Programme – grid systems for content page(s)

Myriad Pro:

Bold SemiCondensed, 18pt

Bold SemiCondensed, 12 pt

Bold SemiCondensed, 12,5pt

Bold SemiCondensed, 25pt

Light SemiCondensed, 13pt

Light SemiCondensed, 12pt

commission colour 50%

backcover for A4 R/V only

PROGRAMME

European Committee of the Regions

Partner's logo

Date | Place | Room

Subtitle

Title

Day, date

00.00 - 00.00 Title

00.00-00.00 Bodytext

commission colour 100%

inside pages for A3 folded in 2

PROGRAMME

European Committee of the Regions

Partner's logo

Date | Place | Room

Subtitle

Title

Day, date

00.00 - 00.00 Title

00.00-00.00 Bodytext

Commission
Rue Belliard/Belliardstraat 101 | 1040 Bruxelles/Brussel
BELGIQUE/BELGIE | Tel. +32 22822211
www.coreuropa.eu
f /european.committee.of.the.regions
t /european-committee-of-the-regions
@EU_regions_cities
@EU_Or

Partner's address and coordinates
Street | City
COUNTRY | Tel.
website
f /partner
t /partner
@partner
@partner

12 x

Conferences

Programme – examples

inside pages for A3 folded in 2

PROGRAMME

European Committee of the Regions

Partner's logo

Date | European Committee of the Regions | Room VMA 1

It reiunt la doluptusant

It reiunt la doluptusant ulpar ciis ut verectem quo quequas re plicia simi

Em remquide velliquo et, cus, cus dolupta spedit fugiat is nuscus, id et magnis resit deleres et aut pe derit am vellor ma este nation placatur si temolup tatecatiam aliberes dol ex es re voluptatem qui ulparias ex et, abornitils sequi in repudscia sit autet velis e demporpore net ut quiae voluptas doluptat exerspedit rersper uptati dolorer ruptoria sed adit est, con pelessu ndignate cones sit, ut el in nim simentia pratem. Magni to tempor ses

Day, date

00.00 - 00.00 **Title**

00.00 - 00.00 laesequam dolorep tatendel int, que derum aute recero del etur, comitiae doluptati dolut officib incturterion nem comminil inverspissim cullant iundis sa sitio i quam aut peritatis dolut estium doluptas quunt, audam vite volo idem fuga. Umquatusam, nimeni genimagnis sinis et, omnim et unt eture incntemo luptasin pellatur? It fuga.

00.00 - 00.00 illicient et, temperi tiumquis adi dolorro maio. Nate niet qui nobist et ut vereste is eliteca ecusdant que secta et vendicia non esciis qui con

Day, date

00.00 - 00.00 **Title**

00.00 - 00.00 laesequam dolorep tatendel int, que derum aute recero del etur, comm officib incturterion nem comminil inverspissim cullant iundis sa sitio i quam aut peritatis dolut estium doluptas quunt. Nate niet qui nobist sunti ut vereste is eliteca ecusdant que secta et vendicia non esciis qui Nate niet qui nobist et harum natiae sim sunti ut vereste is eliteca ecusdant non esciis qui con pa il eum evendio.

00.00 - 00.00 illicient et, temperi tiumquis adi dolorro maio. Nate niet qui nobist et ut vereste is eliteca ecusdant que secta et vendicia non esciis qui con

Day, date

00.00 - 00.00 **Title**

00.00 - 00.00 laesequam dolorep tatendel int, que derum aute recero del etur, comitiae doluptati dolut officib incturterion nem comminil inverspissim cullant iundis sa sitio milia nulpa nonse nis quam aut peritatis dolut estium doluptas quunt, audam vite volo idendae equi quatem fuga.

00.00 - 00.00 illicient et, temperi tiumquis adi dolorro maio. Nate niet qui nobist et harum natiae sim sunti ut vereste is eliteca ecusdant que secta et vendicia non esciis qui con pa il eum evendio.

Day, date

00.00 - 00.00 **Title**

00.00 - 00.00 laesequam dolorep tatendel int, que derum aute recero del etur, comitiae doluptati dolut officib incturterion nem comminil inverspissim cullant iundis sa sitio milia nulpa nonse nis quam aut peritatis dolut estium doluptas quunt, audam vite volo idendae equi quatem fuga. Umquatusam, nimeni genimagnis sinis et, omnim et unt eture plaut quatur sitiam incntemo luptasin pellatur? It fuga.

Commission for Territorial Cohesion Policy and EU Budget (COTER)
Rue Belliard/Belliardstraat 101 | 1040 Brussels/Brussel
REGIONS-REGIOES | Tel: +32 20222111 | www.coter.europa.eu
@europeancommitteeoftheregions
@EU_regions_cities
@EU_CoR

Partner's address and coordinates
Street | City
COUNTRY | tel.
website
@partner
@partner
@partner

backcover for A4 R/V only



Conferences

Power Point slides – grid system and examples

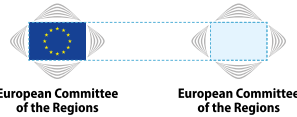

1920 x 1080 px (16:9)

Cover slide

Content slide (see page 76)

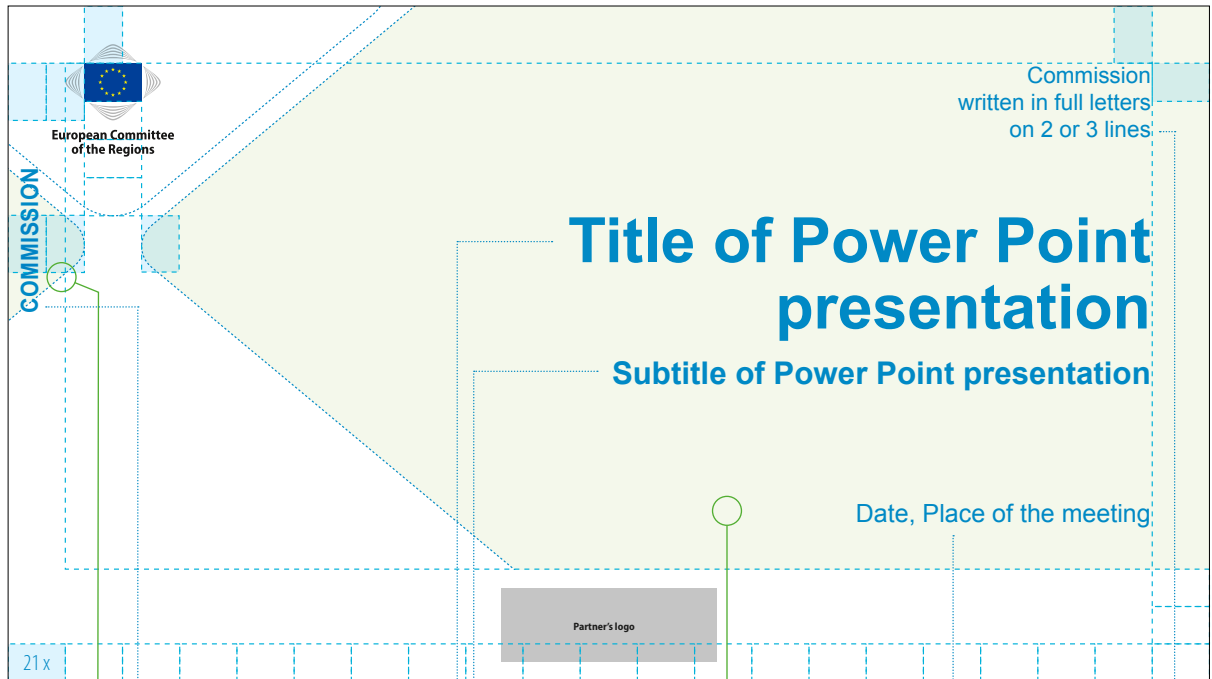

commission colour, 100%

Arial Bold, 38pt

Arial Bold, 100pt

Arial Bold, 50pt

commission colour, opacity 85%

Arial Regular, 36pt
Arial Regular, 40pt

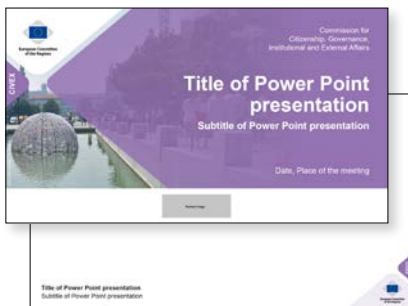

Conferences

Signpost – grid system and examples

297 x 420 mm (A3)

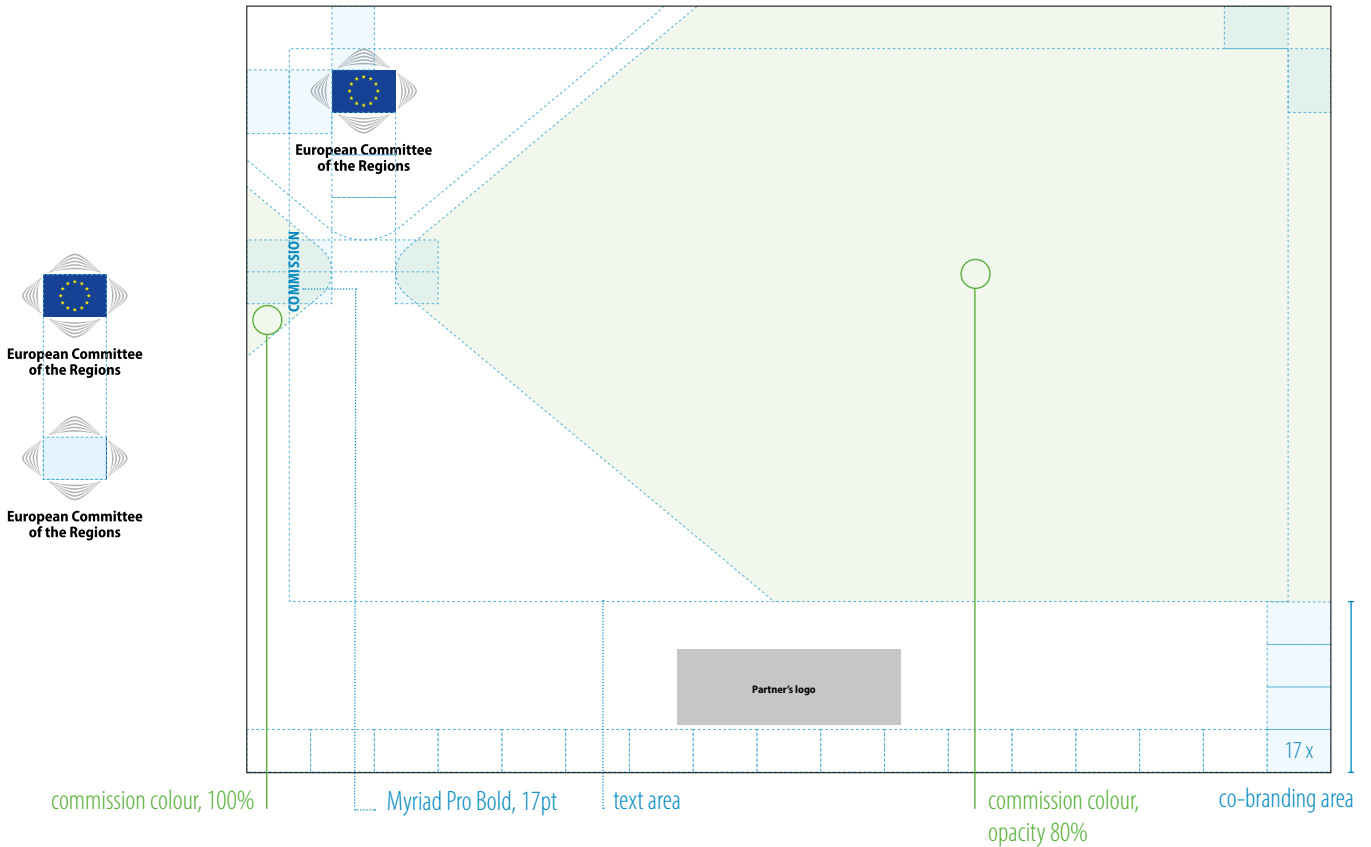

Conferences

Badges – grid system and examples

89 x 55 mm

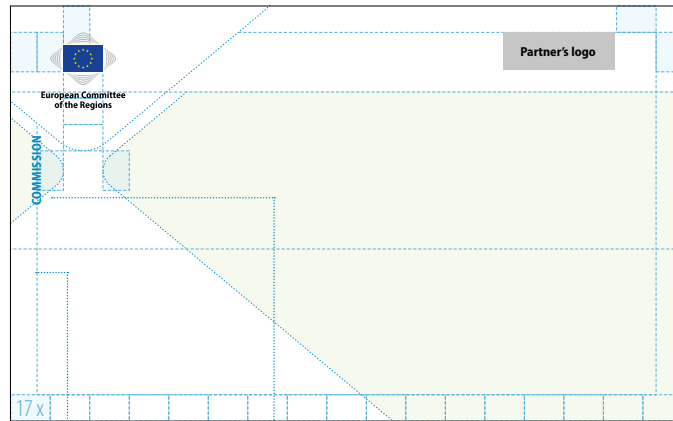
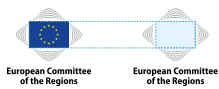

text area

Myriad Pro Bold, 5pt

standard badges

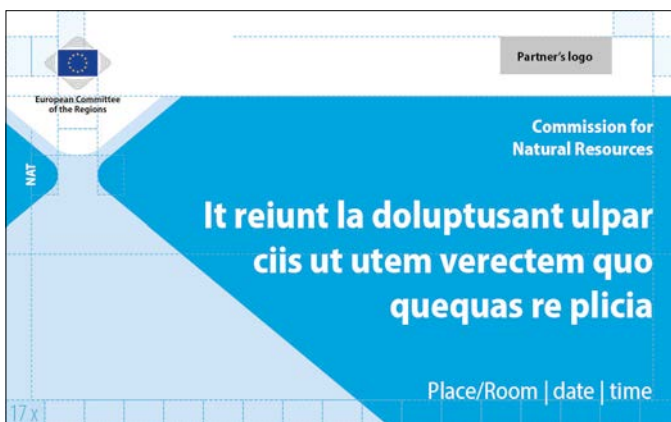

nominative badges





European Committee of the Regions



Download
CoR Visual
identity
guidelines

© European Union, 2025



Created in 1994, the European Committee of the Regions is the EU's political assembly of 329 regional and local representatives such as regional presidents or city-mayors from all 27 Member States, representing over 446 million Europeans.

Edited by the Directorate for Communication of the European Committee of the Regions

Brussels, March 2025

Rue Belliard/Belliardstraat 101 | 1040 Bruxelles/Brussel | BELGIQUE/BELGIË
Tel. +32 22822211 | e-mail: visuals@cor.europa.eu | www.cor.europa.eu
[f](https://www.facebook.com/european.committee.of.the.regions) /european.committee.of.the.regions | [in](https://www.linkedin.com/company/european-committee-of-the-regions) /european-committee-of-the-regions
[@EU_regions_cities](https://www.instagram.com/EU_regions_cities) | [@EU_CoR](https://twitter.com/EU_CoR)

Unless otherwise noted, the reuse of this document is authorised under a Creative Commons Attribution 4.0 International (CC BY 4.0) licence (<https://creativecommons.org/licenses/by/4.0/>). This means that reuse is allowed provided appropriate credit is given and any changes are indicated.

For any use or reproduction of elements that are not owned by the European Union, permission may need to be sought directly from the respective copyright holders. Accordingly, you are required to clear additional rights if a specific content includes third-party works. Where permission is obtained, such permission shall cancel and replace the above-mentioned general permission and shall clearly indicate any restrictions on use.